



## Document Revision Log

---

<b>Date</b>	<b>Description of Change</b>
03/2015	Added section on Lithium Battery Carton Markings and Safety Document Requirements
02/2015	Deleted section: Pallets Containing Date Sensitive Product
02/2015	The DBL fold has been created to replace the prior version of the N fold
11/2014	Slightly revised master carton barcode label placement
08/2014	Removed packaging “M” – Coats/Sweaters as packaging “I” is the same pack method
08/2014	Added section on QVC-OWNED MARKS AND PHONE NUMBERS
07/2014	Added Packaging N – Compact B Fold/Half Method
06/2014	Several format changes were made and some other minor edits



# Table of Contents

Document Revision Log .....	1
Table of Contents .....	2
<b>1. General Packaging for Individual Saleable Unit .....</b>	<b>6</b>
1.1. QVC PACKAGING GOAL .....	6
1.2. OVERVIEW .....	6
1.2.1. <i>The Transportation and Distribution Environment</i> .....	6
1.3. PACK RECIPE .....	8
1.4. VENDOR RESHIPPIERS .....	8
1.4.1. <i>Automation Ready Vendor Reshippers/Cartons</i> .....	8
1.4.2. <i>Minimum Carton Strength Requirements</i> .....	9
1.4.3. <i>Minimum Edge Crush Test (ECT) Requirements</i> .....	10
1.5. INTERNAL CUSHIONING AND IMMOBILIZATION MATERIALS .....	10
1.6. CARTON SEALING REQUIREMENTS .....	12
1.6.1. <i>Taping</i> .....	12
1.6.2. <i>“H-Pattern” Taping</i> .....	14
1.6.3. <i>Banding</i> .....	15
1.7. SPECIAL REQUIREMENTS FOR “LARGE PACKAGES” .....	15
1.7.1. <i>Packaged-Products over 70 lbs</i> .....	16
1.8. PACKAGED PRODUCTS GREATER THAN 2.0 CUBIC FEET .....	17
1.9. LENGTH + GIRTH .....	17
1.9.1. <i>Length plus Girth Calculation</i> .....	18
1.10. DIMENSIONAL WEIGHT .....	18
1.10.1. <i>Dimensional Weight Calculation</i> .....	18
1.11. ACCEPTABLE QVC PACKAGED-PRODUCT SIZES AND WEIGHTS .....	19
1.11.1. <i>Additional Shipping Charges</i> .....	21
1.12. QVC DISTRIBUTION CENTER PACKAGED PRODUCTS SIZE CONSTRAINTS .....	21
1.13. VENDOR JIFFY BAG PACKAGING SPECIFICATIONS .....	21
1.14. VENDOR BUBBLE JIFFY BAG & POLYBAG SIZE REQUIREMENTS .....	22
1.14.1. <i>Void Space Examples: Vendor Jiffy &amp; Polybag</i> .....	22
1.15. DROP SHIPPED PACKAGED PRODUCTS .....	23
1.16. POLYBAG AND FILM REQUIREMENTS AND LABELING .....	24
1.16.1. <i>TOY items using a polybag or film</i> .....	24
1.16.2. <i>NON-TOY items using a polybag</i> .....	24
1.17. PROTECTIVE CHIPBOARD/CORRUGATE - REQUIRED FOR ALL SOFT GOODS MERCHANDISE .....	26
1.17.1. <i>Required Protective Chipboard Size</i> .....	27
1.18. HAZARDOUS MATERIAL CARTON MARKING REQUIREMENTS .....	28
1.19. LITHIUM BATTERY CARTON MARKING AND SAFETY DOCUMENT REQUIREMENTS .....	31
1.19.1. <i>Package Markings for Products Shipped Including Lithium Cell or Batteries</i> .....	31
1.19.1.1. <i>Lithium Ion / Lithium Metal cell or battery packed IN the product</i> .....	32
1.19.1.2. <i>Lithium Ion / Lithium Metal cell or battery packed WITH (not installed) the product</i> .....	32
1.19.2. <i>Lithium Marking and Safety Document Carton Placement</i> .....	33
1.20. QVC-OWNED MARKS AND PHONE NUMBERS .....	33
<b>2. Accessories; Special Packaging Requirements .....</b>	<b>34</b>
2.1. INTERNAL PACKAGING .....	34
2.1.1. <i>Polybags</i> .....	34
2.1.2. <i>Protective Chipboard/Corrugate</i> .....	35
2.1.3. <i>Other</i> .....	35
2.2. INCLUSIONS .....	35
2.3. INSERTS .....	35
2.4. FOLDING AND PRESENTATION GUIDELINES .....	35



# QVC QA Packaging & Labeling Guidelines – All Commodities

- 3. Apparel; Special Packaging Requirements ..... 37
  - 3.1. INTERNAL PACKAGING ..... 37
    - 3.1.1. Polybags ..... 37
    - 3.1.2. Protective Chipboard/Corrugate ..... 38
  - 3.2. INCLUSIONS ..... 38
  - 3.3. INSERTS ..... 38
  - 3.4. SHIPPING CARTONS ..... 38
  - 3.5. GARMENT ON HANGER (GOH) ..... 39
    - 3.5.1. GOH - Special Permission Required ..... 39
  - 3.6. ILLUSTRATED FOLDING AND PACKAGING GUIDELINES ..... 39
    - 3.6.1. Packaging B – Shirts/Tee Shirts/Big Shirts/Tunics/Fine Gauge Sweaters ..... 40
    - 3.6.2. Packaging C – Pants ..... 41
    - 3.6.3. Packaging K – Pants With Front Crease ..... 41
    - 3.6.4. Packaging D – Bulky Sweaters, Jean Jackets & Blazers/Coats ..... 42
    - 3.6.5. Packaging E – Skirts ..... 42
    - 3.6.6. Packaging F – Dresses ..... 43
    - 3.6.7. Packaging F – Robes ..... 43
    - 3.6.8. Packaging G – 2/3/4 Piece Sets ..... 44
    - 3.6.9. Packaging H – Coats without Hangers ..... 44
    - 3.6.10. Packaging I – Coats/Sweaters ..... 45
    - 3.6.11. DBL – Compact Double Fold Method ..... 46
    - 3.6.12. Packaging Q – Garment on Hanger ..... 47
- 4. Home Textiles; Special Packaging Requirements ..... 51
  - 4.1. INTERNAL PACKAGING ..... 51
    - 4.1.1. Polybags ..... 51
    - 4.1.2. Protective Chipboard/Corrugate ..... 52
  - 4.2. INSERTS ..... 52
  - 4.3. SHIPPING CARTONS ..... 52
  - 4.4. FOLDING ..... 53
  - 4.5. SPECIAL REQUIREMENTS FOR RUG PACKAGING ..... 54
    - 4.5.1. Package Components/Carpet Roll ..... 54
    - 4.5.2. Wrapping ..... 55
    - 4.5.3. Closure of Wrapping ..... 55
    - 4.5.4. Rug Shipping Dimensions ..... 56
- 5. Hardgoods, Beauty, & Cosmetics Special Packaging Requirements ..... 58
  - 5.1. GENERAL ..... 58
  - 5.2. FIRST-PIECE QA SAMPLE PREPARATION AND SUBMITTALS ..... 58
  - 5.3. VENDOR RESHIPPIERS ..... 58
    - 5.3.1. Packaging for TSV and High Volume PO's ..... 59
    - 5.3.2. High Graphics on Packaged-Products ..... 59
  - 5.4. LIQUIDS PACKAGING ..... 59
    - 5.4.1. Liquid; Special Packaging Requirements ..... 60
  - 5.5. PACKAGE TESTING ..... 61
    - 5.5.1. QVC ISTA 1A Package Testing ..... 62
      - 5.5.1.1. QVC's ISTA 1A Test Procedure ..... 62
    - 5.5.2. ISTA 3A Package Testing ..... 65
      - 5.5.2.1. Products Requiring ISTA 3A Testing (Effective September, 2011) ..... 65
      - 5.5.2.2. QVC's ISTA 3A Protocol ..... 68
      - 5.5.2.3. Third-Party Package Testing Process ..... 68
      - 5.5.2.4. Third-Party Test Labs ..... 69
    - 5.5.3. QVC "Small Bag" Package Testing ..... 70
    - 5.5.4. Additional ISTA Test Procedures ..... 73
  - 5.6. FINISHED GOODS PACKAGING AUDITS ..... 74
  - 5.7. PACKAGED-PRODUCT DAMAGE ..... 74



# QVC QA Packaging & Labeling Guidelines – All Commodities

- 5.7.1. *Display Box Damage* ..... 75
- 5.7.2. *Minor Degradation*..... 75
- 5.7.3. *Unacceptable Package Degradation* ..... 75
- 5.8. BEAUTY & COSMETIC PACKAGING PRESENTATION ..... 75
  - 5.8.1. *Retail Price Point and Acceptable Packaging*..... 75
  - 5.8.2. *Beauty TSV Packaging*..... 76
  - 5.8.3. *Giftable Product Packaging* ..... 76
  - 5.8.4. *Multi-Component Packaging*..... 76
  - 5.8.5. *Retail Packaging*..... 76
  - 5.8.6. *Vendor Carton ID : Product OD Void Space* ..... 77
    - 5.8.6.1. *Void Space Examples: Vendor Carton*..... 77
  - 5.8.7. *Packaging Class and Acceptable Forms of Packaging* ..... 80
- 5.9. WHY PACKAGES FAIL FIRST-PIECE EVALUATION ..... 81
- 5.10. PACKAGING INDUSTRY CONTACTS..... 81
- 5.11. LITERATURE AND DOCUMENTS ..... 82
- 6. Jewelry: Special Packaging Requirements ..... 83**
  - 6.1. INTERNAL & EXTERNAL PACKAGING ..... 83
    - 6.1.1. *Polybags* ..... 83
      - 6.1.1.1. POLYBAG SIZE REQUIREMENTS ..... 83
    - 6.1.2. *Packaging* ..... 84
  - 6.2. EXCLUSIONS..... 84
  - 6.3. TARNISH PREVENTION/SULFUR-FREE, CHLORINE-FREE ..... 85
  - 6.4. PRESENTATION CASES..... 85
    - 6.4.1. *QVC-Provided Presentation Case* ..... 85
    - 6.4.2. *Vendor Presentation Case* ..... 85
  - 6.5. SPECIFIC PRODUCT-TYPE PACKAGING ..... 86
    - 6.5.1. *No Metal on Metal*..... 86
    - 6.5.2. *Sets*..... 86
    - 6.5.3. *Rings*..... 86
    - 6.5.4. *Necklaces, Bracelets, Anklets, Pins, Pendants Without Chains* ..... 86
    - 6.5.5. *Pendants With Chains*..... 87
    - 6.5.6. *Earrings*..... 87
    - 6.5.7. *Watches*..... 87
- 7. Packaging for Shipment to a QVC Distribution Center ..... 88**
  - 7.1. OVERVIEW ..... 88
  - 7.2. PACKAGING..... 88
    - 7.2.1. *Definitions of QVC Packaging Components*..... 88
  - 7.3. ACCESSORIES, APPAREL, HARDGOODS, COSMETICS & HOME TEXTILES SPECIAL INBOUND PACKAGING REQUIREMENTS ..... 89
    - 7.3.1. *Primary packaging* ..... 89
    - 7.3.2. *Vendor reshipper* ..... 89
    - 7.3.3. *Inner carton* ..... 89
    - 7.3.4. *Master Carton*..... 89
      - 7.3.4.1 *Max Master Carton Dimensions & Weight*..... 90
    - 7.3.5. *Gaylord Packaging*..... 91
    - 7.3.6. *Pallet*..... 92
      - 7.3.6.1 *Mixing SKUs on a Pallet*..... 92
  - 7.4. JEWELRY; SPECIAL INBOUND PACKAGING REQUIREMENTS ..... 92
    - 7.4.1. *Primary Package* ..... 92
    - 7.4.2. *Inner Pack Requirements*..... 93
    - 7.4.3. *Master Cartons* ..... 94
      - 7.4.3.1. *Minimum & Maximum Master Carton Dimensions & Weight*..... 94
      - 7.4.3.2. *Packing Multiple Small Master Cartons into an Over Box* ..... 95
      - 7.4.3.3. *Mixing SKUs in a Master Carton*..... 96
    - 7.4.4. *Standardized Pack Quantities*..... 96



# QVC QA Packaging & Labeling Guidelines – All Commodities

7.4.5.	<i>Pallet</i> .....	97
<b>8.</b>	<b>Package Barcode Labeling Requirements</b> .....	<b>98</b>
8.1.	THE SALEABLE UNIT BARCODE LABEL.....	98
8.1.1.	<i>Saleable Unit Label Requirements</i> .....	98
8.1.2.	<i>Saleable Unit Label Placement</i> .....	99
8.1.2.1.	Label placement for corrugate vendor reshipper:.....	100
8.1.2.2.	Label placement for Apparel product in a polybag:.....	100
8.1.2.3.	Label placement for garments on hangar:.....	101
8.1.2.4.	Label placement for shoes and boots:.....	101
8.1.2.5.	Label placement for rolled carpet:.....	102
8.1.2.6.	Label placement for undersized products:.....	102
8.2.	THE INNER CARTON LABEL.....	103
8.2.1.	<i>Inner Carton Label Placement</i> .....	103
8.2.2.	<i>Inner Polybag Placement</i> .....	104
8.3.	THE MASTER CARTON BARCODE LABEL .....	104
8.3.1.	<i>Master Carton Label Requirements</i> .....	104
8.3.2.	<i>Use of Carton Markings Versus A QVC Master Carton Label</i> .....	106
8.3.3.	<i>Master Carton Label Placement</i> .....	106
8.4.	THE PALLET LABEL.....	107
8.4.1.	<i>Pallet Label Requirements</i> .....	108
8.4.2.	<i>Pallet Label Placement</i> .....	109
8.4.3.	<i>Multiple Box Items</i> .....	110
8.5.	PRE-EXISTING VENDOR CARTON LABELS .....	110
<b>9.</b>	<b>QVC Barcode Format Requirements</b> .....	<b>111</b>
9.1.	APPROVED LABEL SUPPLIERS .....	111
9.2.	DISPLAYING THE QVC SKU IN A HUMAN READABLE FORMAT.....	111
9.3.	GENERAL BAR CODE LABEL REQUIREMENTS .....	112
9.4.	BAR CODE FORMATS.....	113
9.4.1.	<i>Code 128B Requirements</i> .....	113
9.4.1.1.	Encoding the QVC SKU into a C128B bar code .....	114
9.4.2.	<i>UPC-A &amp; EAN-13 requirements</i> .....	115
9.5.	REQUIRED CROSS REFERENCE DATA.....	116
9.6.	BAR CODE APPROVAL PROCESSES .....	117
<b>10.</b>	<b>Jewelry; Special Labeling &amp; Barcode Format Requirements</b> .....	<b>118</b>
10.1.	APPROVED LABEL SUPPLIERS .....	118
10.2.	GENERAL BAR CODE LABEL REQUIREMENTS .....	118
10.3.	SALEABLE UNIT BAR CODE SPECIFICATIONS .....	118
10.3.1.	<i>Saleable Unit Label placement</i> .....	119
10.4.	INNER PACK BAR CODE SPECIFICATIONS.....	119
10.4.1.	<i>Inner Carton Label Placement</i> .....	120
10.5.	MASTER CARTON BAR CODE SPECIFICATIONS.....	120
10.5.1.	<i>Master Carton Label Placement</i> .....	120
10.6.	PALLET LABEL SPECIFICATIONS.....	120



# 1. General Packaging for Individual Saleable Unit

## 1.1. QVC Packaging Goal

Our goal is to ensure that all shipments to our QVC DC's and our customers arrive without any damage and that each unique product uses the most cost effective packaging when transporting the merchandise.

## 1.2. Overview

As a direct response retailer, QVC utilizes so-called small parcel couriers such as the United States Postal Service (USPS) and the United Parcel Service (UPS) to ship merchandise to our customers. As such, QVC has somewhat different packaging requirements and preferences than traditional retailers.

By following the requirements and guidelines outlined in this chapter, merchandise will be better able to survive transit and handling, thereby minimizing customer dissatisfaction and customer returns. In addition, the Shipping and Handling (S&H) charges to our customers can be controlled or reduced, which is to everyone's benefit.

Under no circumstances shall QVC accept products that cannot, in its sole judgment, survive transit and handling, in the expected distribution environment, without incurring unacceptably high levels of damage.

Whenever possible, QVC relies on generally recognized performance specifications to determine the suitability of packaging and its ability to protect products from transit- and handling-related damage. However, based on the experience we have gained after having shipped over one billion (and counting!) packages, QVC recognizes the limitations of some generally recognized performance specifications. For some types of products and packages, QVC may require compliance with design or material specifications.

### 1.2.1. The Transportation and Distribution Environment

The first step in designing effective packaging is to understand the hazards that a package will encounter in the transportation and distribution environment. By failing to understand this environment, too little packaging, or too much packaging, is likely to result. Too little packaging will result in unacceptably high levels of transit damage. Too much packaging wastes scarce resources, adds unnecessarily to the solid waste stream, and costs money for labor and packaging materials.

The distribution environment consists of all the handling, storage, transportation and other events to which a package is subjected, from the time of its manufacture until it reaches the final consumer. Consider, for example, a consumer product manufactured in China, and a partial list of the hazards that may be encountered before the product reaches the ultimate consumer:



## QVC QA Packaging & Labeling Guidelines – All Commodities

1. Staged on an incompletely protected loading dock during monsoon rains, waiting for truck to arrive
2. Impact shocks and drops during container loading
3. Compression on bottom layers, due to being stacked 10' high
4. (Very) bumpy roads via truck transit to the railroad
5. Drop impact when put onto railroad carrier
6. Vibration during rail transit
7. Rail car coupling/decoupling
8. Ambient conditions: 100° F, 70% relative humidity (thus reducing strength of corrugate)
9. Dropped three feet by crane onto oceangoing vessel
10. Swaying/vibration on vessel; small hole in container lets in rain; wide temperature variation during ocean transit from Asia to the United States.
11. Vessel unloading
12. Truck or railroad loading
13. Vibration; bumps, potholes, running over curbs during truck transit
14. Receipt at QVC receiving dock
15. Impact shocks and drops during the palletization process
16. Possibly stacked two pallets high
17. Individual customer orders picked and delivered to the pack line; order packed; travels upside down through one mile of conveyors until reaching roller conveyor into truck; impacts, sliding or tumbling from one level of conveyor to another; lateral forces experienced during conveyor jams
18. Random package loading into UPS trailer; compression forces on bottom packages
19. UPS pick-up, truck/train transit to UPS hub; vibration, bumps, potholes
20. Sortation and conveying at UPS hub
21. Truck transit to local UPS facility; temperature in Minnesota is -7° F.
22. Random package loading into UPS “package car” for delivery to customer
23. Dropped from UPS package car; dragged up steps to customer’s door.

The above represents merely a partial listing of the handling and hazards that each and every package may encounter. The vendor must design packaging so that the product survives all of these hazards:



- Vibration
- Mechanical Shock
- Static and Dynamic Compression
- Drop Impacts
- Abrasion
- Deformation
- Temperature
- Relative Humidity
- Water Damage
- Tampering

### 1.3. Pack Recipe

During the first piece QA evaluation QVC gives each individual sku a “pack recipe”. A pack recipe includes the weight, dimensions and special packing instructions for the single saleable unit. To keep the single order s&h a constant, a sku can only have one pack recipe for the life-cycle of the item unless its entire inventory is depleted from the QVC warehouse.

### 1.4. Vendor Reshippers

Based on the product type and/or size, QVC may require the vendor to overbox the product in a reshippable container (a reshipper).

When a vendor reshipper is required, the following criteria must be met:

1. A reshipper is a sturdy outer package which QVC can ship directly to our customers with minimum processing and handling. A reshipper may be the primary product packaging, or an overbox.
2. A suitable reshipper protects and cushions merchandise within a heavy unbleached brown kraft corrugate container.
3. A reshipper should have minimal carton markings and graphics, be securely sealed, and meet package testing requirements.
4. A reshipper may require more than just an overbox, additional internal packaging within the overbox may be required.

#### 1.4.1. Automation Ready Vendor Reshippers/Cartons

Vendor reshipper/cartons that are automation ready will reduce processing time at the QVC DC and therefore ensure speedy delivery to our customers. Thus, where





## QVC QA Packaging & Labeling Guidelines – All Commodities

possible, QVC looks to maximize vendor reshipper/carton automation and most times this can be achieved with little to no added material cost or shipping charges. QVC's minimum and maximum dimensions for automation are 9"x6"x1.5" – 36"x24"x18.5".

**Effective August 1<sup>st</sup>, 2013, First Piece QA samples that meet all points 1-4 below must be packaged in a vendor reshipper/carton that has minimum dimensions of 9"x6"x1.5". Products that meet these guidelines but are not packaged accordingly will be subject to a QA rejection.**

1. The product is being brought into QVC as a new item number (skn or sku)
2. The product is packaged in a vendor reshipper and/or the purchase order is greater than 5,000 units
3. The packaged-product weight is equal to or greater than 1lb. (Note: This requirement is based on protecting increased transportation costs)
4. The product is shipping to the QVC DC, not Drop Ship

### 1.4.2. Minimum Carton Strength Requirements

QVC requires that all products be packaged so that they arrive at QVC without damage, can be handled within QVC's distribution environment without damage, and are protected against moisture, humidity, dirt and abrasion.

Most products are required to be shipped in bulk to QVC in fiberboard containers, generally in corrugated containers. Following is an outline of QVC's minimum carton strength requirements.

1. Merchandise should be packaged in fiberboard containers that conform to National Motor Freight Classification "Item 222, Specifications for Fiberboard Boxes (Corrugated or Solid)". Each carton must bear a legible certificate of a carton manufacturer on the outside surface, guaranteeing that the carton conforms to such specifications. Domestic corrugate suppliers should have no difficulty manufacturing and certifying to these specifications.
2. Boxes must be made of single-wall or double-wall corrugated fiberboard having proper bending qualities. The facings must be firmly glued to the corrugating medium at all points of contact. The corrugating medium must be made of board weighing no less than 26 pounds per 1,000 square feet.
3. Boxes must comply with the minimum edge crush (ECT) test as outlined below, with such tests being conducted in accordance with Technical Association of Pulp and Paper Industry (TAPPI) Official Test Methods.



### 1.4.3. Minimum Edge Crush Test (ECT) Requirements

Maximum Weight Of Package (lbs.)	Minimum Burst Test (lbs./sq. in.)	Minimum Edge Crush Test (lbs./in. width)
< 20	150	28
21 – 35	200	32
36 – 50	250	40
51 – 65	275	48
66 – 80	275/350	48/51
81 – 100	350	51
101 – 120	400	61
121 – 140	400	61
> 140	500	71

1. Because QVC sells its merchandise through televised presentation and demonstration, the expensive three- or four-color point-of-sale display cartons that may be preferred by other retailers are not preferred by QVC. Heavy brown kraft corrugate with minimal markings is preferred.
2. Corrugated cartons must be “new”. Previously used corrugate is not permissible.
3. Corrugate made with recycled paperboard is acceptable, so long as the minimum edge crush test and minimum burst strength requirements are satisfied. The Fiberboard Box Association encourages the use of the “Corrugated Recycles” symbol on corrugate boxes.

## 1.5. Internal Cushioning and Immobilization Materials

The primary function of packaging is to absorb or modify the energy from impacts, shaking, rattling, rolling, squeezing and dropping experienced from the distribution environment. The product must be protected and preserved in its original undamaged condition from the point of manufacture to receipt by our customers.

Internal packaging materials are used to cushion, secure and immobilize the product within the shipping container. Failure to completely cushion and adequately immobilize products and their components can lead to abrasion and breakage. Inadequate amounts of internal cushioning, and improperly or poorly used internal cushioning and immobilization materials are the leading cause of in-transit damage and delivery failure.



## QVC QA Packaging & Labeling Guidelines – All Commodities

When possible, packaging materials should be sustainable in nature. Materials that can be easily recycled, reused and reduced are preferred.

**Figure 1 - Acceptable Internal Packaging Materials**

Acceptable	Not Acceptable
Molded & Fabricated EPS <sup>1</sup>	Cornstarch Loose Fill
Polyurethane Foam in Place	EPS Loose Fill
Molded Paper Pulp Forms	Popcorn
Molded & Fabricated “Poly” Foams	Shredded Newspaper
Encapsulated Air Sheets (Bubblewrap®) <sup>2</sup>	Shredded Paper
Inflatable Air Bags <sup>3</sup>	Straw
Corrugated Pads, Diecuts, Partitions, Build-ups, Scored Sheets & Shapes	Stretch or Shrink Wrap/Film
Solid Fiberboard Pads, Diecuts, Partitions, Build-ups, Scored Sheets & Shapes	Wadded Newspaper
Tissue Paper <sup>2</sup>	
Poly Foam Sheeting and Wraps <sup>2</sup>	
Plastic Polybags (Polyethylene or Polypropylene only)	
Suspension Packs – Plastic Film/Corrugated	
Wadded Paper (Not preferred)	

When using the various forms of internal packaging, the following criteria must be met:

1. Any molded and/or fabricated Expanded Polystyrene (EPS) (e.g. Styrofoam) material used for interior packaging must be of high quality with consistent density. The EPS foam utilized must not display conditions of excessive fracturing, flaking, dusting, and/or disintegration. These conditions not only affect the performance of the foam but also make for a very poor presentation to our customers. Packaged-products using poor quality EPS will be rejected.
2. When using bubblewrap, poly foam sheeting wraps and tissue paper, repeatability and consistency of use are critical. Once a successful and acceptable packaged-product design is achieved, the same amount, size, type and pack out methodology using these internal cushioning and immobilization materials must be consistent in order to protect the products. With bubblewrap, one side is flat and the



## QVC QA Packaging & Labeling Guidelines – All Commodities

other side has all the bubbles on it. The most effective use of bubblewrap is to wrap the item with the bubble side facing in on the product you want to protect.

3. Instead of packing single bags, keep air bags “chained” together as much as possible. This will help to keep the product protected and braced more effectively. Use enough air bags to fill out the interior with the flaps of the container supported and square when secured with tape. Do not over pack or “crown” the box. Over stuffing boxes will make it difficult to apply shipping labels and envelopes, to stack the boxes later in the shipping cycle, and could potentially cause the boxes to burst.
4. Small product components must be enclosed in a zip lock, heat sealed or tape sealed PE or PP polybag. Staple sealing is not acceptable.

Beyond merely filling the void between the product and the box, cushioning absorbs shocks. Corrugate inserts or molded polystyrene can also increase the stacking strength of the entire package, so that the product itself does not support any of the compressive loads encountered in the distribution process. Reinforcing corners is particularly effective.

Corrugate inserts or molded polystyrene can also increase the stacking strength of the entire package, so that the product itself does not support any of the compressive loads encountered in the distribution process. Reinforcing corners is particularly effective.

### 1.6. Carton Sealing Requirements

All cartons must be securely sealed to prevent damage to the contents that may be caused by moisture, humidity, dirt, pest infestation, handling and tampering. In addition to protecting the contents, a securely sealed carton indicates to the final consumer an assurance that items purchased are “new” and have not experienced tampering.

#### 1.6.1. Taping

When sealing a package, the following criteria must be met:

1. Boxes must be securely closed or sealed parallel to the opening of the box with a high quality pressure-sensitive or reinforced kraft tape that is at least 2 inches (5 cm) wide. Water-activated tape is discouraged, in that it frequently is not applied properly and may open in transit.



## QVC QA Packaging & Labeling Guidelines – All Commodities

2. Before sealing, minimize any gaps between the flaps forming the center seam
3. Self-erecting containers are usually not permitted and never recommend for any packaged-products weighing more than 2.2 lbs (1Kg). If a self-erecting container is used it **MUST** have a strip of packaging adhesive tape over all seams of the carton.

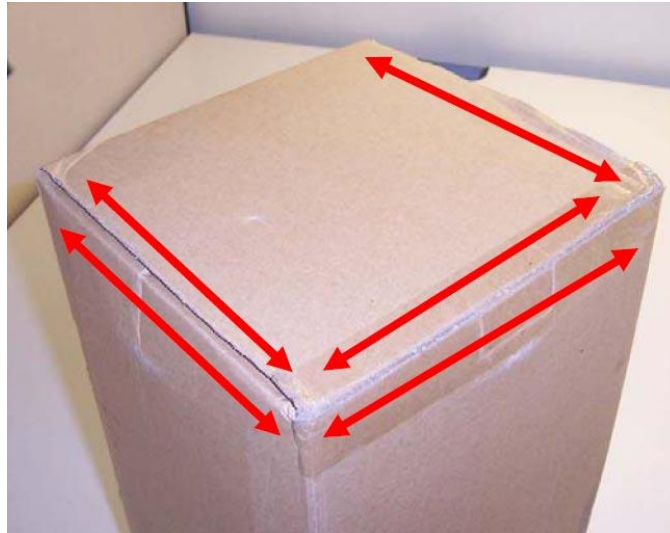

**Figure 2 - Taping Tuck-Top Boxes**

1. Tuck top cartons must be sealed with tape along all edges of the opening.
2. The Vendor must ensure that required carton markings are not covered with tape.
3. Bar codes are not to be placed over carton seams nor covered with tape.
4. Staples are not permitted on packages less than 70 pounds.
5. All packages in excess of 70 lbs (31.8 Kg) must be packaged in double wall corrugate, preferably with seams that are stitched or stapled, not glued.
6. For most packages, QVC recommends that the "6-strip" or "H-pattern" taping method be used as illustrated below in section 1.6.2



### 1.6.2. “H-Pattern” Taping

Using the 6-strip or H-pattern taping method is especially important for larger or heavier packages to prevent carton handlers from using the unsealed carton flaps as “hand-holes”. The QVC QA Department may request or require vendors to use the 6-strip or H-pattern taping method.

---

**NOTE:** Cartons coming open in transit are one of the leading reasons for package delivery failure.

---

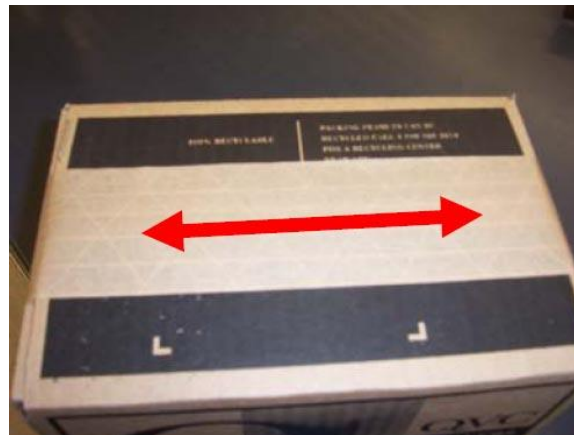

**Figure 3 - H-Pattern Taping, Strip 1**

1. Tape parallel to the opening of the box

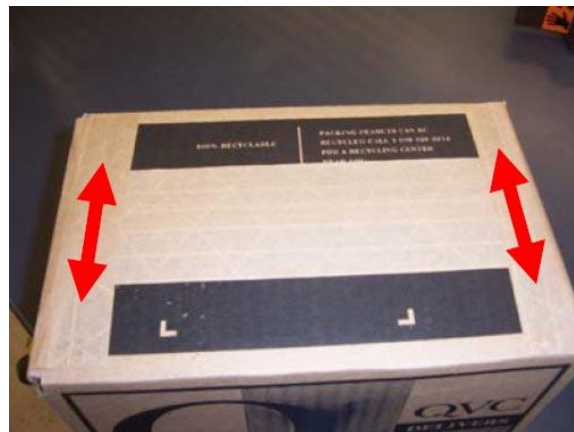

**Figure 4 - H-Pattern Taping, Strips 2 and 3**

2. Apply tape on the edges perpendicular to the first strip to form the letter “H”
3. Repeat for the other side of the package



### 1.6.3. Banding

QVC generally does not allow the use of banding (strapping) on packaged-products received at our distribution centers. Banded products cannot be safely put on QVC conveyors.

1. Banding is not permitted on any products with outside dimensions less than or equal to 36" X 24" X 24" (91.5 cm X 61 cm X 61 cm) unless explicitly approved in advance by QVC Corporate Quality Assurance.
2. When approved for use, banding should not act as the sole means of keeping the packaged-product intact and securely closed.
  - i. Either pressure sensitive or reinforced kraft tape should also be applied to the packaged-product.
3. Packaged-products that weigh in excess of 70 lbs (31.8 Kg) are approved for banding.
4. Polypropylene banding is the only approved type of banding. Metal banding is not permitted.
5. The tension, including appropriate sealing of the bands, must be such that the bands remain intact and tight throughout the distribution cycle.
6. Multiple banding, including banding in two directions, may be required in order to adequately contain the product.
7. The use of banding edge protectors (90° plastic angles) or similar devices is strongly suggested for banded products. These protectors will aid in distributing the load and tension of the bands so as to mitigate and avoid cutting into the edges of the packaging.
8. The First-Piece QA Sample of any product that has been approved for banding must be banded in the same manner as the deliverable product.

### 1.7. Special Requirements for “Large Packages”

“Large Packages” are defined by QVC as those packages whose length plus girth is between 84” (213 cm) and 130” (330 cm), and whose weight is between 40 pounds (18.2 kg) and 150 pounds (68.2 kg). Due to the manner in which such large packages are handled, and the excessive damage complaints that QVC has experienced with such packages, QVC has special guidelines and requirements for large packages, as follows:

1. Reshippers: All large packages must pass package integrity testing in the vendor reshipper packaging. QVC will not overpack large packages.



## QVC QA Packaging & Labeling Guidelines – All Commodities

2. Immobilization/Cushioning: The contents of large packages must be immobilized within the package using custom-fitted corrugate or foam inserts. It is important to use foam of sufficient strength and thickness for heavy packages; if the foam is too weak, it may break when subjected to mechanical shock or impact.
3. Carton Sealing: When taped, large packages must be sealed using the “6-strip” or “H-pattern” taping method.
4. Package Orientation: Packages must be designed to withstand shipping and handling in any package orientation, even upside-down. It is strongly recommended that highly elongated packages be shipped in their upright position whenever possible.
5. Human (Ergonomic) Factors: Package handlers can generally be expected to keep products in what they believe to be the package’s upright position. Take advantage of this expected behavior. Carton markings, including orientation arrows, should encourage handlers to keep the package in its most favorable orientation. Make sure that the contents are not packed upside-down in the package. Indicate the weight, in both pounds and kilograms, on the package so that handlers can prepare mentally and physically for the task of moving the package.

---

**NOTE:** UPS require a “Heavy Package Label” for all packages weighing in excess of 70 pounds (32 kg).

---

6. So long as they do not detract from the package’s overall ability to withstand forces and impacts, reinforced “hand holes” are encouraged. Well-placed hand holes will encourage shipping in the most favorable orientation. In addition, a package with hand holes would be expected to experience fewer drops.

### 1.7.1. Packaged-Products over 70 lbs

---

**NOTE:** The vendor is responsible for the procurement of any required “Heavy Package Labeling” and the proper placement of such labels on all reshippers.

---

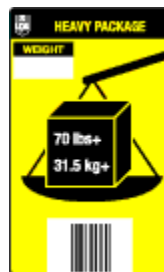

**Figure 5 - UPS Heavy Package Label**





## QVC QA Packaging & Labeling Guidelines – All Commodities

Any packaged-product that weighs 70 pounds (31.8 kilograms) or more will require “Heavy Package” labels to be placed on two adjacent sides of the package. These labels are available from UPS (United Parcel Service).

### 1.8. Packaged Products Greater Than 2.0 Cubic Feet

Vendors are advised that QVC takes an additional \$3.75 margin on packaged-products in excess of 2.0 cubic feet in order to recoup additional handling and storage costs. Cubic feet of packaged-product = (outside length in inches X outside width in inches X outside depth in inches) divided by (1728 cubic inches per cubic foot). In some cases, a small adjustment to the packaging can eliminate this charge. When possible, it is to both QVC and our vendor’s advantage to ship packaged-products that are less than 2 cubic feet.

For Example: A box is 18” Long by 14” Wide and 14”High.  
Cubic Ft = (L X W X H) / 1728  
Cubic Ft = (18” X 14” X 14”) / 1728 “/ft<sup>3</sup>  
Cubic Ft =(3528 inches<sup>3</sup>) / 1728 inches<sup>3</sup> / foot<sup>3</sup>  
Cubic Ft =2.04 cubic feet.

Note that by making the package only 1” shorter in only one dimension, the package will be less than 2.0 cubic feet, and \$3.75 cheaper to ship.

### 1.9. Length + Girth

The combined dimension of Length plus Girth is commonly used to define the size of a package. The graphic and sample calculation below describes how to determine this value:



### 1.9.1. Length plus Girth Calculation

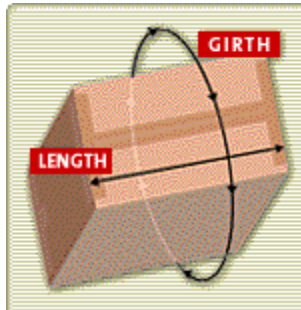

*Length* is the longest side of a package or object.

*Girth* is the distance all the way around the package or object at its widest point perpendicular to the length.

Add Length and Girth measurements together to obtain total package size.

**For Example: A box is 24” Long by 18” Wide and 12”High.**

$$\text{Length} + \text{Girth} = L + (2 \times W) + (2 \times H)$$

$$\text{Length} + \text{Girth} = 24” + (2 \times 18”) + (2 \times 12”)$$

$$\text{Length} + \text{Girth} = 24” + 36” + 24”$$

$$\text{Length} + \text{Girth} = 84”$$

When possible, it is to both QVC and our vendor’s advantage to ship packaged-products that have a length plus girth of less than 130”.

## 1.10. Dimensional Weight

UPS determines shipping charges for all Air shipments (Next Day or 2nd Day) plus all Ground Shipment packages that have a volume of 3 cubic feet or larger. When possible, it is to both QVC and our vendor’s advantage to ship packaged-products that are less than 3 cubic feet.

### 1.10.1. Dimensional Weight Calculation

In order to more accurately reflect the cost of shipping small heavy packages and large light packages, UPS has introduced Dimensional Weight. A weight/volume calculation is performed to determine the shipping costs of a package.

Example: A package is 23.25” Long by 18” Wide and 17.5” High, and weighs 27 lbs, 6 oz. Calculations are for US Domestic shipments, other calculation factors apply to International shipments.



## QVC QA Packaging & Labeling Guidelines – All Commodities

1. Determine the Length, Width and Height dimensions used for calculation by rounding any fractional dimension to the nearest whole inch:
  - (1) 23.25" Long rounds down to 23"  
18" Wide remains 18"  
17.5" High rounds up to 18"
2. Calculate the volume of the packages in cubic inches:
  - (1) Volume = L" X W" X H"  
Volume = 23" X 18" X 18"  
Volume = 7452 cubic inches
3. Determine the actual weight of the package and round any fractional weight UP to the next higher pound:
  - (1) 27 lbs, 6 oz is rounded up to 28 lbs.  
Actual Weight = 28 lbs
4. Determine the Dimensional Weight:
  - (1) IF you are using UPS Ground Shipment, AND the package volume is LESS THAN 5184 cubic inches, use the Actual Weight of the package.
  - (2) IF you are using UPS Ground Shipment, and the package volume is 5184 cubic inches or larger, OR if you are using UPS Air Shipment:  
Divide the volume of the package by 198 and round UP to the next full pound.

In our example:

  - Dimensional Weight = package volume / 198
  - Dimensional Weight = 7452 / 198
  - Dimensional Weight = 37.6 lbs
  - Dimensional Weight = 38 lbs
5. When the packaged-product exceeds 3 cubic ft, shipping costs are calculated using the LARGER of the Dimensional Weight OR the Actual Weight. In this example, the shipping costs are based on the Dimensional Weight of 38 lbs, even though the actual (rounded-up) weight was only 28 lbs. When the packaged-product is less than 3 cubic ft the shipping costs are based off the weight of the package.

### 1.11. Acceptable QVC Packaged-Product Sizes and Weights

QVC ships over 100 million packaged-products to our customers annually using the United States Postal Service (USPS), United Parcel Service (UPS) and common carrier trucks. Each of these means of delivery has size and weight limitations. In addition, QVC's Distribution Centers utilize processing and handling equipment having minimum and maximum dimensional and weight constraints.



## QVC QA Packaging & Labeling Guidelines – All Commodities

In order to be processed on QVC’s automated distribution lines, the minimum outside dimensions reshippers use to package products must be 9” X 6” X 1-1/2” (23 cm X 15.5 cm X 4 cm).

**NOTE:** Vendors are not required to meet QVC’s minimum dimensions for distribution automation.

The maximum package size that QVC can accept for receipt into our distribution centers and also be shipped via small parcel are as follows:

1. Packages up to 150 pounds or 68.04 kilograms
2. Packages up to 165 inches or 419 centimeters in combined length and girth
3. Packages up to 108 inches or 274 centimeters in length

**NOTE:** Any packaged-product that meets one of the three points above cannot ship into QVC distribution centers. Instead, these items may be eligible for Less-Than-Truckload (LTL) and must be drop shipped from the vendor’s facility to our customers. Consult your QVC Merchant and refer to the “Drop Ship Guidelines” on the Vendor QA Website.

Shippable Package-Products					
Longest Dimension	Length + Girth	Weight	Carrier	Comments	
≤108"	130" or less	≤150 lbs.	Small Parcel	N/A	N/A
≤108"	>130" and ≤165"	≤150 lbs.	Small Parcel	Large Package Surcharge applies	Minimum billable weight of 90 lbs.
>108"	Any	Any	LTL	Not available from QVC DC's	NA
Any	>165"	Any	LTL	Not available from QVC DC's	N/A
Any	Any	>150 lbs.	LTL	Not available from QVC DC's	N/A



### 1.11.1. Additional Shipping Charges

Additional handling [AH] fee are applied for packages where:

1. One side exceeds 60".
2. A second side exceeds 30" [but no side exceeds 60"].
3. A package exceeds 70 lbs actual weight.
4. If the package is subject to a large package surcharge [LPS], it will not be assessed an AH fee.

## 1.12. QVC Distribution Center Packaged Products Size Constraints

QVC has three internal classifications for reshippers: automation eligible; non-automation eligible; and conveyor ineligible. These classifications are defined below in order of preference.

---

**NOTE:** At times, only minor changes are required in the vendor's packaging to accommodate the automation eligible requirements. In these cases the QVC QA Department may request or even require vendors to make such changes. Please see section [Automation Ready Vendor Reshippers](#), for further details.

---

1. An automation eligible reshipper will have minimum outside dimensions of 9" X 6" X 1-1/2" (23 cm X 15.5 cm X 4 cm) and may not have outside dimensions greater than 36" X 24" X 24" (91.5 cm X 61 cm X 61 cm). The customer's packslip and the QVC Program Guide are automatically inserted into a 9" X 6" (23 cm X 15 cm) envelope, which in turn is "hot glued" onto the shipping carton.
2. A non-automation eligible reshipper will have minimum outside dimensions of at least 4-5/8" X 4" X 1-1/2" (12 cm X 10 cm X 4 cm) in order for the QVC shipping label to be applied to the box. The packslip and QVC Program Guide are placed inside the package for non-automatable reshippers.
3. A conveyor ineligible reshipper will have outside dimensions greater than or equal to 36" X 24" X 24" (91.5 cm X 61 cm X 61 cm). In addition, packaged-products that weigh in excess of 70 lbs (31.8 Kg) or have approved banding cannot be put onto QVC conveyors.

## 1.13. Vendor Jiffy Bag Packaging Specifications

Vendors may pack small robust products in bubble jiffy mailers. These products must be able to pass [QVC's "Small Bag" Package testing](#). In addition, vendor bubble jiffy mailer packaging must meet the below requirements. These requirements are intended to improve the package quality and presentation,



reduce transportation costs, and improve product-put-away (PPA) rates caused by buyer's remorse.

1. The outer substrate of the bubble jiffy bag must be brown kraft paper, poly (plastic) should be avoided
2. The brown kraft paper bubble jiffy bag may be self adhesive or heat seal, taped bags are not accepted
3. The two dimensional brown kraft paper bubble jiffy bag must have minimum dimensions of at least 9"x7"
  - a. Products requiring a brown kraft paper bubble jiffy bag larger than 9"x7" must follow the [Vendor Bubble Jiffy Bag & Polybag Size Requirements](#)
4. The inner bubble lining must be a minimum ¼" in diameter
5. Lastly, it is recommended that the brown kraft paper not contain graphics or Brand labeling

### 1.14. Vendor Bubble Jiffy Bag & Polybag Size Requirements

Smaller robust products may be packaged in vendor bubble jiffy bag or polybag packaging. The footprint of the bag must have minimum dimensions of 9"x7". To eliminate unnecessary void space, products requiring a bag larger than 9"x7" must use the following formula to determine the package dimensions:

**ID of Vendor Jiffy Bag or Polybag** = Product length+2" (or less) X Product Width+2" (or less) X Product Height

#### 1.14.1. Void Space Examples: Vendor Jiffy & Polybag

##### Example 3: Unacceptable Jiffybag/Polybag Dimensions

The product dimensions are 8"x3"x1"

The inside bag dimensions are 14"x5"x1"

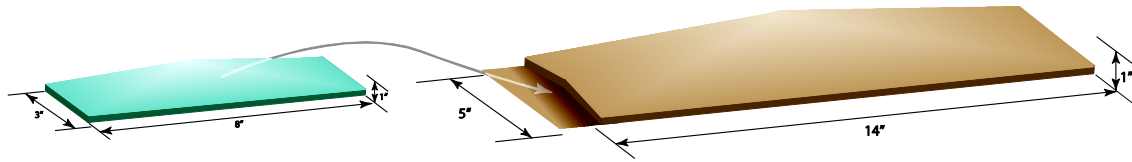

Example 3: Unacceptable Jiffy/Polybag Dimensions

In this example, the bag is **not acceptable** because the length dimensions of the bag equals 14" and shouldn't be greater than 10" ( $8" + 2" = 10"$ )

#### Example 4: Acceptable Jiffybag/Polybag Dimensions

The product dimensions are 9"x7"x2"

The inside bag dimensions are 10"x9"x2"

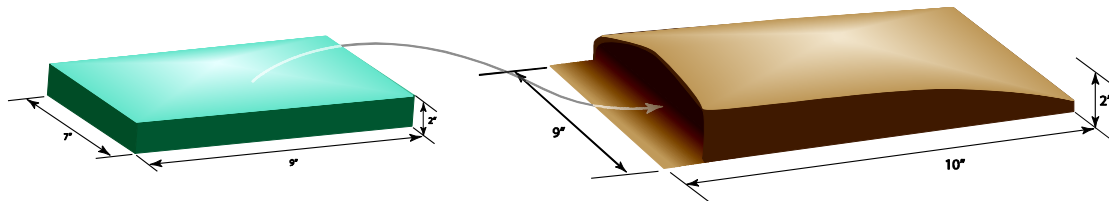

Example 4: Acceptable Jiffy/Polybag Dimensions

In this example, the bag is **acceptable** because all dimensions of the bag are less than or equal to the product dimensions +2"

## 1.15. Drop Shipped Packaged Products

QVC has designated certain products as being appropriate for drop shipment directly to the customer; other products may be considered on a case-by-case basis. Normally drop shipped products include:

- Highly perishable products (food or plants).
- Personalized products.
- Packaged-products that exceed the QVC acceptable packaged-product sizes. (These items weigh more than 150 pounds [70 kilograms], are greater than 165 inches [419 centimeters] in length and girth combined, or are greater than 108 inches [274 centimeters] in any one direction.)



All drop shipped merchandise is required to comply with all Packaged-Product requirements and testing as outlined in this document.

### 1.16. Polybag and film requirements and labeling

(To be used for accessories, apparel, home textiles, hardgoods, cosmetics & jewelry)

Please note QVC’s polybag requirements are broken down by toy and non-toy specifications. Please see below for examples of toy items.

Toy	
Toy cars, trucks, boats, etc.	Building blocks/kits
Stuffed animals/dolls	Toddler tool sets
Toddler games/devices	Children books

#### 1.16.1. TOY items using a polybag or film

Toy products using a polybag and/or film do not require a suffocation warning label, however, if used, the polybag and/or film must meet points 1 or 2 below.

1. Actual wall thickness must be at least 1.5 mils (0.0015 in. or 0.0381 mm) thick.
2. Alternatively, sheeting with a thickness of less than 1.5 mils (0.0015 in. or 0.0381 mm) shall be perforated with defined holes so that a minimum of 1% of the area has been removed over any area of 1.18 X 1.18in.

Respectively, if points 1 or 2 are not met the polybag and/or film cannot be used as packaging for a toy item.

**NOTE:** Please reference F963-11 for more information on Toy polybag and film requirements.

#### 1.16.2. NON-TOY items using a polybag

**NOTE:** To avoid having to use a suffocation warning label for a Non-toy polybag package, QVC suggests the total poly thickness be equal to or greater than 1.0 mil.





## QVC QA Packaging & Labeling Guidelines – All Commodities

A suffocation warning label is required only if points 1 and 2 are both met.

1. An opening greater than 5 in. (12.7 cm) when placed flat.
2. Actual wall thickness less than 1.0 mil (0.001 in. or 0.0254 mm).

If points 1 and 2 are both met the polybag must then meet points 3-5. Moreover, if not both points 1 and 2 are met a suffocation warning label is not required.

### 3. Required Statement:

**WARNING: PLASTIC BAGS CAN BE DANGEROUS. KEEP AWAY FROM BABIES AND CHILDREN. DO NOT USE IN CRIBS, BEDS, CARRIAGES OR PLAYPENS. THE THIN FILM MAY CLING TO NOSE AND MOUTH AND PREVENT BREATHING. THIS BAG IS NOT A TOY.**

The suffocation warning statement must be printed in English for the USA.

### 4. Required Font size

Font Sizes	
<i>Minimum font sizes are required per added length &amp; width (1L+1W) of poly-bag.</i>	
Length & Width (1L+1W)	Font Size
60" or more	<b>24 point</b>
40"-59"	<b>18 point</b>
25-39"	<b>14 point</b>
<25"	<b>10 point</b>

### 5. Required Location:

If the length plus width (1L+1W) of the polybag is equal to or greater than 25", the suffocation warning label must appear on both sides of the bag.

If the length plus width (1L+1W) of the polybag is less than 25", the suffocation warning label may only appear on one side of the bag.

Additionally, the suffocation warning must repeat at 20" intervals on a polybag with a length plus width (1L+1W) of 40" or more.



The suffocation warning label must be printed or indelibly attached by a label to the polybag film.

---

**NOTE:** QVC's Non-Toy polybag and film requirements are a consolidation of several US State, Local, and Federal requirements.

---

## 1.17. Protective Chipboard/Corrugate - Required for all soft goods merchandise

Protective chipboard is used to protect soft goods merchandise from sharp objects like a box cutter when trying to open the container. Product categories like accessories, apparel, and home textile have soft goods merchandise thus require protective chipboard for both vendor reshipper and master carton packaging.

### Sketch 1 Item in Box with Chipboard

Place chipboard at bottom of empty box, then insert product.

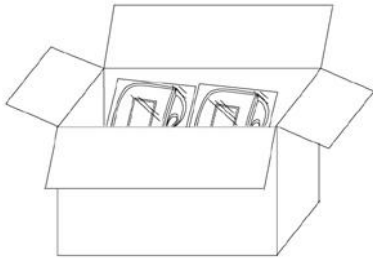

Next, place another piece of protective chipboard on top of contents and then seal the container.

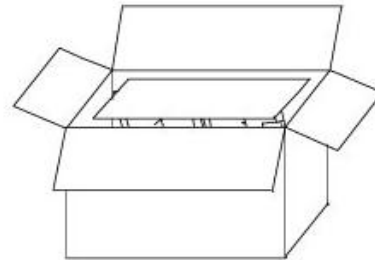

When using protective chipboard, the following criteria must be met:

1. Protective chipboard cut sheets must have a minimum caliper (thickness) of 20 point (.020). Corrugated cut sheets should be of sufficient thickness to prevent knife punctures and cuts.
2. Chipboard is required for the saleable unit and master carton packaging.

---

**NOTE:** If the soft goods merchandise is shipping in a vendor reshipper and a master carton only the vendor reshipper box requires protective chipboard.

---

3. Protective chipboard or corrugated cut sheet must be placed inside the box, on both the top and bottom of the total contents.
4. There must be no internal or external sharp projections or edges. The use of staples or metal stitching as a means of closure is not permitted.
5. Exceptions for not requiring protective chipboard for soft goods merchandise are as follows:



6. Center Special Slotted Containers (CSSC) **do not** require protective chipboard. This type of carton has the two flaps on the top and bottom of the container that meet in the middle, thus providing a protective barrier to the product.
7. Full Overlap Slotted Containers (FOL) **do not** require protective chipboard. This type of carton has the two flaps on the top and bottom of the container that overlap one another, thus providing a protective barrier to the product.
8. Center Special Overlap Slotted Container (CSO) **do not** require protective chipboard. This type of carton has the two flaps on the top that overlap one another and two flaps on the bottom of the container that meet in the middle thus providing a protective barrier to the product.

---

**NOTE:** Chipboard or corrugated cut sheets are not allowed to be used for folding of individual saleable units. For examples, it is unacceptable to place chipboard on a scarf and fold the scarf around the chipboard. However, folding with chipboard is acceptable when it's specified in the packaging instruction.

---

#### 1.17.1. Required Protective Chipboard Size

Protective chipboard/corrugate must also be an appropriate size for the shipping carton; it must fit inside the carton without bending, and be large enough to avoid slipping out of place and protect the merchandise.

Vendors are required to follow the formulas below to determine the appropriate dimensions for chipboard and corrugated cut sheet:

LENGTH of chipboard or corrugate = interior length of carton - 4" (10.16 cm)

WIDTH of chipboard or corrugate = (interior width of carton ÷ 2) + 4"  
(10.16 cm)



Example:

Interior Carton Dimensions	Sizing Formula	Appropriate Chipboard/Corrugate Dimensions
22" L (56 cm)	(interior length - 4] 22 - 4	18" L (46 cm)
16" W (41 cm)	(interior width ÷ 2) + 4 (16÷2) + 4	12" W (30 cm)

### 1.18. Hazardous Material Carton Marking Requirements

Title 49 of the United States Code of Federal Regulations (49 CFR) addresses the U.S. Department of Transportation regulations for transporting hazardous material. Some people may be surprised to learn that many common consumer products are considered hazardous for transportation purposes, usually because of their corrosive or flammable nature.

QVC will not offer for sale any product that contains hazardous materials (as defined in 49 CFR 172.101) unless it is eligible for the less restrictive Limited Quantity classification. Items classified as Limited Quantity are Consumer Commodities containing hazardous materials that appear on the 49 CFR 172.101 table, but are granted some exemption due to their form, quantity and packaging.

---

**NOTE:** ALL products deemed Limited Quantity MUST BE 1) packaged in a corrugate carton and 2) marked accordingly

---

QVC requires vendors to comply with all applicable laws and regulations, and therefore to mark both master cartons and saleable unit cartons for items that are classified as consumer commodities with the proper Limited Quantity marking. The Limited Quantity mark must appear consistently on at least one side or end of the package (not being either of the two largest carton surfaces), and should not appear with other markings. (CFR 172.315(a) and 172.315(b).). An example of an acceptable mark is shown below:



## QVC QA Packaging & Labeling Guidelines – All Commodities

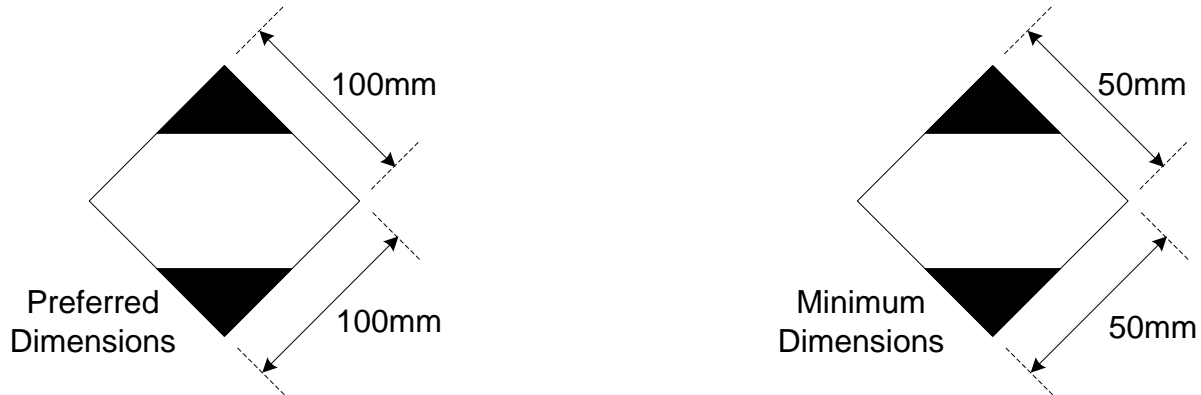

(for reference only – not actual size)

The size of the mark is to be appropriate to the size of the box. The preferred size is 100mm x 100mm (approximately 4”) on each side. However, you may use a mark that is as small as 50mm x 50mm (approximately 2”) on each side.

---

**NOTE:** The Limited Quantity mark can be applied in a horizontal method “square” if the box side is greater than 2-1/2” H and less than 3-1/2” H.

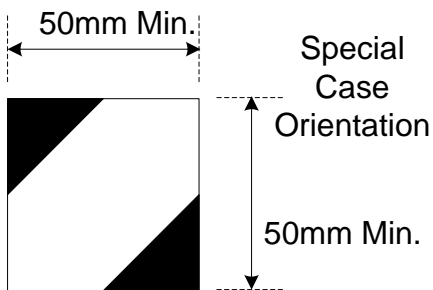

---

Placement of the mark is also very important. Due to the method your product is processed, handled and shipped in the QVC distribution environment, the following QVC requirements also must be met:

- At least one Limited Quantity mark is required on the smallest or medium panel of the box. See example #1 below, reference location (a). The mark cannot be covered by box sealing tape unless clear tape is used.
- If the smallest **AND** medium sized panels are smaller than 2-1/2” H, then you will need to apply the mark to **BOTH** of the largest flat panels. See example #2 below, reference location (b) or redesign the shipping box.

---

**NOTE:** the **ONLY** exception to the above bullet is that if the individual unit corrugate carton is smaller than 4-5/8” x 4” x 1-1/2”, then only one mark is required.

---



## QVC QA Packaging & Labeling Guidelines – All Commodities

- If all sides of the carton are equal, then you must mark two (2) sides. See example #3 below, reference location (c).
- At no time shall the Limited Quantity mark be applied to the panel that contains the box opening seam. See all examples below, reference location (d).

---

**NOTE:** The Limited Quantity mark cannot wrap around an edge or corner.

---

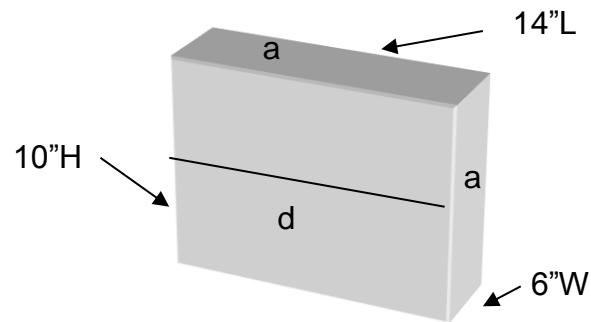

# 1

b and opposite  
side of b

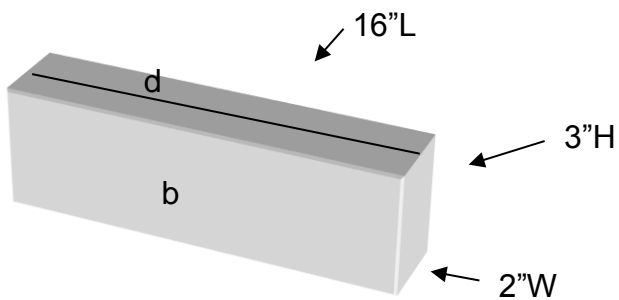

# 2

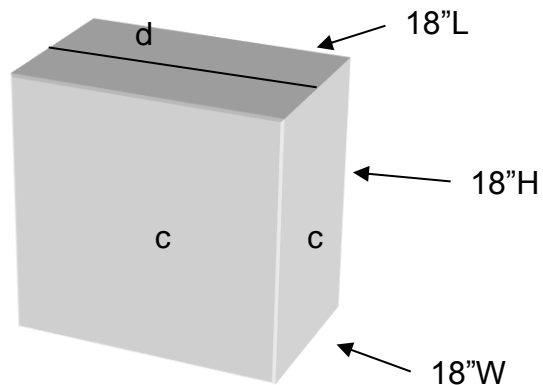

# 3



The marking shown above is for normal Ground transportation. QVC does not ship hazardous materials by air transportation but if your product meets the DOT requirements for a Limited Quantity product shippable by air transport, QVC will accept product with Limited Quantity AIR marking (see example (c) below).

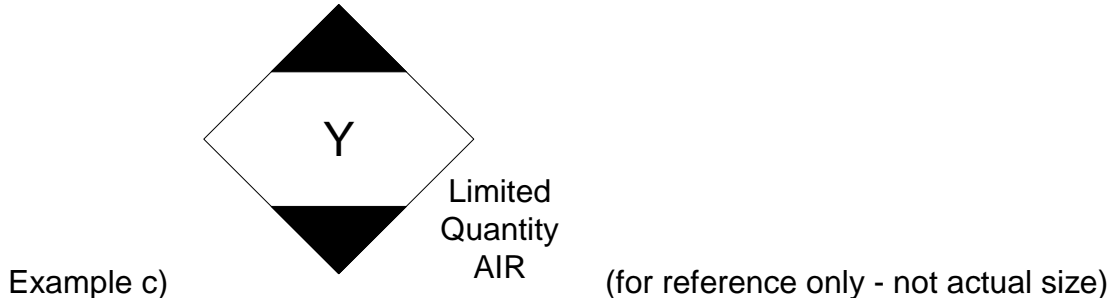

---

**NOTE:** If your product is marked with the Limited Quantity AIR markings it must actually meet the DOT requirements for air transportable products. Failure to meet these requirements is cause for rejection of the product.

---

QVC will continue to accept the older ORM-D marking for product received at the QVC Distribution Centers prior to December 31, 2012. Beginning January 1, 2013 all products received at the Distribution Centers MUST have the new Limited Quantity marking.

## 1.19. Lithium Battery Carton Marking and Safety Document Requirements

In order for QVC to ship some lithium battery products, the outer reshipper carton must include a lithium handling battery mark and a safety document in accordance to the 49 CFR 173.185. Please note, not all lithium battery products require a lithium battery handling mark and a safety document on the package. In fact, when it's not required, it's illegal to include the lithium battery handling mark and safety document to the package. Please carefully read the below guidelines to determine if your package requires a lithium battery handling mark and safety document.

---

**NOTE:** ALL products requiring a lithium handling mark and safety document MUST BE 1) packaged in a shippable vendor corrugate carton and 2) marked accordingly

---

### 1.19.1. Package Markings for Products Shipped Including Lithium Cell or Batteries



### 1.19.1.1. Lithium Ion / Lithium Metal cell or battery packed IN the product

- Not exceeding the allowable limit
- No additional markings or shipping documentation required
- Examples include, but not limited to: electronic tablet, wireless speaker, built-in, manufacturer installed

### 1.19.1.2. Lithium Ion / Lithium Metal cell or battery packed WITH (not installed) the product

- Requires a Lithium Handling Mark, see image directly below



- This marking must measure at least 105mm (4.1”) X 74mm (2.9”)
  - Identification of cell or battery type
    - Lithium Ion or Lithium Metal
  - Contact phone number
    - Contact MUST be available 24 hours a day, 7 days a week in case of an emergency
  - Contact MUST be able to access MSDS of lithium cell or battery
- The package also requires a Safety Document, see image directly below

• This package must be handled with care. A flammability hazard exists if the package is damaged.

• If this package is damaged in transportation, it must not be loaded until the condition of the contents can be verified. The batteries contained in this package must be inspected for damage and may only be repacked if they are intact and protected against short circuits.

• For more information about the batteries contained in this package, call the following telephone number: \_\_\_\_\_





## QVC QA Packaging & Labeling Guidelines – All Commodities

- This document can be a peel off label or a paper inserted into a clear plastic pouch

### 1.19.2. Lithium Marking and Safety Document Carton Placement

- When required, both the saleable unit vendor carton and master carton must include a lithium handling mark and safety document
- The lithium handling mark should be placed on the smallest or medium size carton panel
- The lithium handling mark must lay flat on the carton panel
  - Folding the marking over the carton edge or corner is NOT acceptable
- The lithium handling mark cannot be covered by other carton markings or labels
- When possible, the safety document should be applied to the same carton panel as the lithium handling mark
- Although not suggested, the safety document can be wrapped around the edge of the carton

---

**NOTE:** Lithium battery product must also be packed in a manner to prevent short circuits, movement within the outer package and accidental activation of the equipment. In addition, the package-product must be able to pass a 1.2 meter drop test on all 6 faces of the package. If you are logged into the Vendor Portal, you can [click here](#) to view QVC's Battery guidelines for battery spec requirements. The document is also available on the Portal under QA Guidelines/Requirements>Hardgoods>QA Hardgoods Manual and Guidelines.

---

### 1.20. QVC-OWNED MARKS AND PHONE NUMBERS

Vendors are not permitted to use the QVC logo, any QVC-owned marks, or any QVC phone numbers on any merchandise or product literature (including product and packaging labels), except in certain narrowly-defined circumstances. Any merchandise that uses the QVC logo, QVC-owned marks, or QVC phone numbers will be rejected, unless expressly approved, in writing, in advance by the QVC Legal Department and Merchandising Management.



## 2. Accessories; Special Packaging Requirements

Accessories are particularly at risk for tearing, soiling and becoming disheveled during shipment and handling. To ensure that accessories are received in a clean and orderly condition, QVC has set forth the following requirements for accessory packaging.

### 2.1. Internal Packaging

Most times, because of the physical characteristics (low fragility) of the product, accessories require little to no internal packaging. However, all accessory items must contain at least a primary package.

#### 2.1.1. Polybags

Polybag packaging must meet the following criteria:

1. Each accessory unit must be packaged in a polybag. Each individual saleable unit must be packaged separately. A saleable unit with multiple pieces (i.e., set) must be packaged together in one master polybag, without taping or tying the pieces together.
2. All polybags must be new. QVC will not accept refurbished or used polybags of any kind.
3. Polybags must be clear (transparent) plastic polyethylene (HDPE).
4. Accessory polybags must have a minimum thickness of 1.5 mil.
5. Polybags must be self adhesive seal and securely closed. Heat seal, taped, tied and stapled polybags are unacceptable.
6. Polybags used to package accessories may have perforated holes within the film.
  - a. QVC recommends accessories made of suede, leathers, skins, etc., be packaged in polybags with perforated holes.
7. The polybag must be the appropriate size for the saleable unit. Polybags that are too large or small will be subject to rejection.
8. Polybags must be consistent (same materials, dimensions, transparency and thickness) throughout the Purchase Order.
9. All accessory polybag and film must meet QVC's specification and labeling requirements, see section [Polybag and Film Requirements and Labeling](#).



### 2.1.2. Protective Chipboard/Corrugate

All soft goods accessory merchandise require protective chipboard/corrugate cut sheet within the vendor reshipper and/or master carton packaging, see section [Protective Chipboard/Corrugate – Required for all Soft Goods Merchandise](#).

### 2.1.3. Other

1. Display boxes must be taped shut.
2. Shoe boxes must be banded with plastic bands.

## 2.2. Inclusions

When using inclusions, the following criteria must be met:

1. Tissue paper should be soft bleached tissue.
2. Metal hangers are unacceptable.
3. Straight pins are unacceptable.
4. Plastic clips are unacceptable.
5. Folding with chipboard or corrugated cut sheet is unacceptable for most accessories. **NOTE:** Folding with chipboard is acceptable when it's specified in the packaging instructions, or if it's essential for certain items (e.g., hosiery).

## 2.3. Inserts

Inserts or instructions must fit inside the polybag without excessive bending or folding. Any insert must receive prior approval from QVC QA during the First-Piece QA Sample Evaluation.

## 2.4. Folding and Presentation Guidelines

Below is QVC's folding and presentation criteria:

1. Each saleable unit must be folded or arranged neatly, and in a manner that is appropriate for the product type.
2. Folded textiles/apparel (e.g., scarves, dickies) must be folded with soft bleached tissue paper to protect the item's shape.
3. Chipboard or corrugated cut sheet should not be used for folding accessories. However, folding with chipboard is acceptable when it's specified in the packaging instruction.
4. Leather items (e.g., shoes, purses) should be filled with soft bleached tissue, or packaging paper in order to maintain the item's shape. (Newspaper is unacceptable.)



## QVC QA Packaging & Labeling Guidelines – All Commodities

5. Shaped hats (e.g., straw hats) should be filled with soft bleached tissue or packaging paper in order to maintain the item's shape. Chipboard may also be used, depending on the product.
6. Hosiery must be folded around chipboard.
7. For belts, the strap should be coiled neatly, and protective cardboard or tissue paper should be wrapped around the buckle/hardware.
8. Any hardware on the item must have a protective covering to prevent scratches.
10. Footwear individually packaged in polybags must meet QVC's polybag and film specification and labeling requirements, see section [Polybag and Film Requirements and Labeling](#). Straps on handbags must be folded inside the polybag.
11. Shoes must be packaged in the same shoe box and box must be banded with plastic bands.



### 3. Apparel; Special Packaging Requirements

Apparel is particularly at risk for tearing, soiling and becoming disheveled during shipment and handling. To ensure that apparel is received in a clean and orderly condition, QVC has set forth the following requirements for apparel packaging.

#### 3.1. Internal Packaging

Most times, because of the physical characteristics (low fragility) of the product, apparel items require little to no internal packaging. However, all apparel items must contain at least a primary package.

##### 3.1.1. Polybags

Polybag packaging must meet the following criteria:

1. Each apparel saleable unit must be packaged in a polybag. Each individual saleable unit must be packaged separately. A saleable unit with multiple pieces (i.e., set) must be packaged together in one master polybag, without taping or tying the pieces together.
2. All polybags must be new. QVC will not accept refurbished or used polybags of any kind.
3. Polybags must be clear (transparent) plastic polyethylene.
4. Apparel polybags must have a minimum thickness of 0.6 mil.
5. Polybags must be self adhesive seal and securely closed. Heat seal, taped, tied and stapled polybags are unacceptable.
6. Polybags used to package apparel items may have perforated holes within the film except for garments given a ["B fold"](#) in the pack recipe.
  - a. Regardless of the pack recipe, QVC recommends garments made of suede, leathers, skins, etc., be packaged in polybags with perforated holes.
7. The polybag must be the appropriate size for the saleable unit. Polybags that are too large or small will be subject to rejection.
8. Polybags must be consistent (same materials, dimensions, transparency and thickness) throughout the Purchase Order.
9. All polybags must meet QVC's polybag and film specification and labeling requirements, see section [Polybag and Film Requirements and Labeling](#).



### 3.1.2. Protective Chipboard/Corrugate

All soft goods apparel merchandise require protective chipboard/corrugate cut sheet within the vendor reshipper and/or master carton packaging, see section [Protective Chipboard/Corrugate – Required for all Soft Goods Merchandise](#).

## 3.2. Inclusions

When using inclusions, the following criteria must be met:

1. Tissue paper should be soft bleached tissue. All tissue paper must be Grade #1 (acid free) and at least 10 lb basis weight material.
2. Metal hangers are unacceptable.
3. Straight pins are unacceptable.
4. Plastic clips are unacceptable.
5. Chipboard or corrugated cut sheet for folding is unacceptable.

## 3.3. Inserts

Inserts or instructions must fit inside the polybag without excessive bending or folding. Any insert must receive prior approval from QVC QA during the Production Sample Evaluation.

## 3.4. Shipping Cartons

When shipping apparel bulk goods to QVC, vendors must pack apparel saleable units in inner and/or master carton packaging. Vendors are not required to use inner cartons; however, QVC QA may suggest inner cartons in order to further protect the saleable units. For apparel bulk goods, shipping cartons must comply with the following requirements, in addition to the general strength, cushioning, and sealing standards outlined in this chapter.

When using a corrugate carton, the following criteria must be met:

1. Whenever an apparel saleable unit, and its protective polybag, comes in direct contact with the interior of the carton, the manufacturer's joint must be glued or taped only. Stapled or stitched joints are not permitted. (This will prevent or minimize apparel and protective bags from being snagged.)
2. There must be no internal or external sharp projections or edges. The use of staples or metal stitching as a means of closure is not permitted.



### 3.5. Garment on Hanger (GOH)

The following are special requirements for apparel items to be shipped on a hanger.

1. No wire or metal hangers are permitted.
2. Tied polybags are unacceptable.
3. For all outerwear and leather, the vendor must consult with the QVC Technical Designer on the packaging and shipping method.
4. Please refer to packaging Q, in the “Folding and Packaging Guidelines” for more details.
5. All GOH moving cartons must contain up arrows to ensure the packaging stays upright during normal transit and handling.

#### 3.5.1. GOH - Special Permission Required

The GOH space in QVC’s Distribution Center is limited and reserved for specific garment and fabric types such as silks, velvets, faux furs, and outerwear. Due to the limited space, the vendor must obtain special permission to ship a GOH.

Written permission must be obtained from Buyer and/or DDGS. If a supplier attempts to arrange for a GOH pick-up without receiving prior QVC permission, the shipment will be rejected and will not be routed for pick-up.

### 3.6. Illustrated Folding and Packaging Guidelines

The manner in which a garment is folded and packaged impacts its appearance after going through transit. This section provides some guideline illustrations on how to fold and package garments for QVC.

The guidelines are only suggestions for methods of folding and finished dimensions. QVC will accept variances from these guidelines within reason.

Each saleable unit, however, must always be folded or arranged neatly, and in a manner that is appropriate for the garment type. Furthermore, folded apparel must be folded with tissue paper to protect the garment’s shape. Chipboard or corrugated cut sheet must never be used for the folding of apparel.



### 3.6.1. Packaging B – Shirts/Tee Shirts/Big Shirts/Tunics/Fine Gauge Sweaters

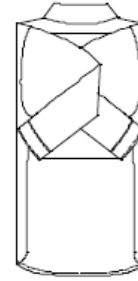
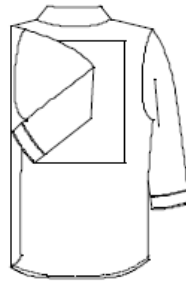

1. Lay item front side down. Place tissue on center back of garment, even with the shoulders. Fold sleeve across back of garment.
2. Fold the second sleeve over top of the other sleeve.

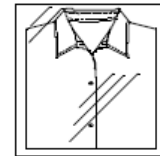

3. Fold up from bottom in half or thirds to a "square" shape. \*Folding may vary based on length of garment.
4. Place folded garment in appropriately sized polybag.





### 3.6.2. Packaging C – Pants

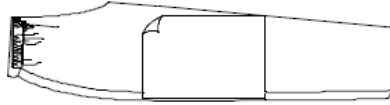
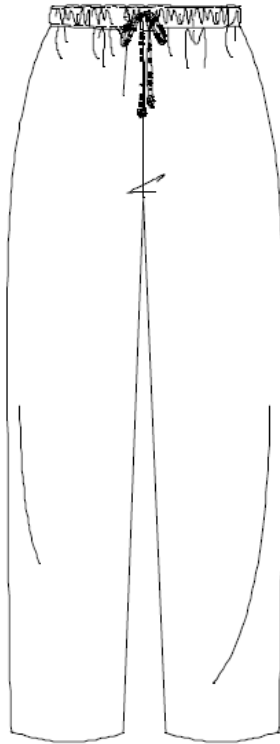

1. Lay item flat with side seams meeting. Place tissue in center of pant.

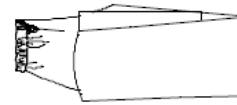

2. Fold pant legs over tissue.

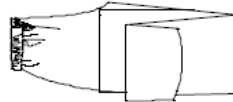

3. Fold pant leg over again (for long pant).



4. Fold top over.



5. Place folded item in appropriately sized polybag.

**NOTE:** See alternate version of fold on next page.

### 3.6.3. Packaging K – Pants With Front Crease

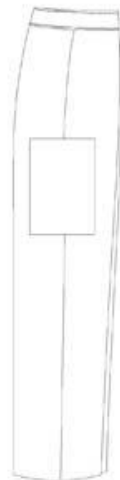
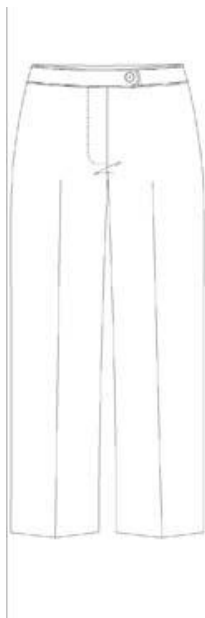

1. Lay item flat lining up the front creases of the pant. Place tissue in the center of the leg.

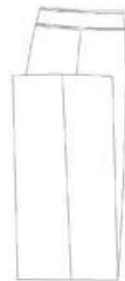

2. Fold legs in half.

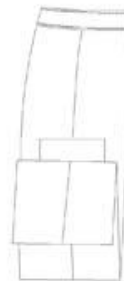

3. Fold leg over again.

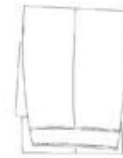

4. Fold top over.



5. Place folded item in appropriately sized polybag.



### 3.6.4. Packaging D – Bulky Sweaters, Jean Jackets & Blazers/Coats

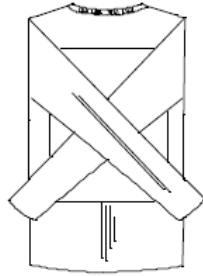

1. Lay item front side down. Place tissue on center back of garment, even with the shoulders. Fold sleeves across back of garment.

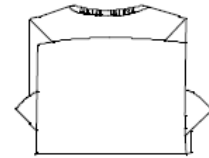

2. Fold up from bottom in half to a "square" shape.

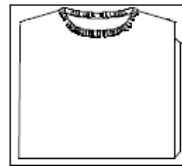

3. Place folded garment in appropriately sized polybag.

### 3.6.5. Packaging E – Skirts

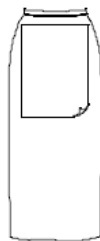
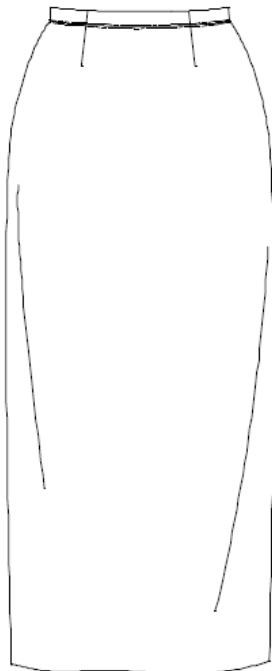

1. Lay item front side down. Place tissue on center of garment just below the waist.

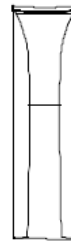

2. Fold sides of skirt toward middle of skirt.



3. Fold skirt up from bottom.

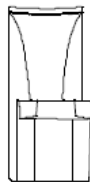

4. Fold bottom of skirt over again. (Long skirts)



5. Fold top of skirt over so that bottom fold is even with waistband.



6. Place folded item in appropriately sized polybag.



### 3.6.6. Packaging F – Dresses

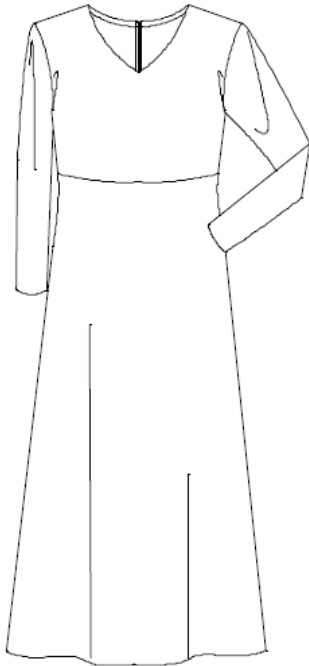

1. Lay item front side down. Place tissue at center back, even with shoulders.



2. Fold sides of bodice even with shoulders. Fold sleeves and sides of dress toward middle of dress.



3. Fold dress up from bottom.



4. Fold top of dress so that neckline meets foldline.

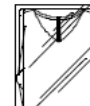

5. Place folded gar appropriately sized polybag.

### 3.6.7. Packaging F – Robes

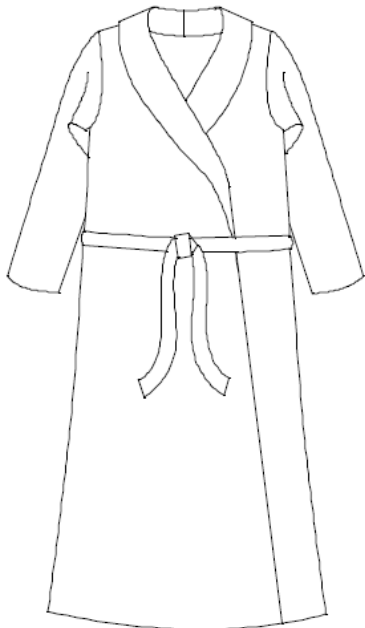

1. Lay item front side down. Place tissue on center of back, even with shoulders.

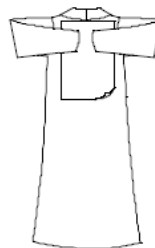

2. Fold sleeves toward center.



3. Fold sides even toward middle, width should be the same for entire length of garment. Fold sleeves again toward middle of garment. Insert folded tie below sleeves.

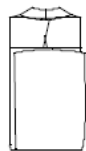

4. Fold bottom up.



5. Fold top of robe so that collar meets bottom fold.



6. Place folded item in appropriately sized polybag.



### 3.6.8. Packaging G – 2/3/4 Piece Sets

**OPTION 1:**  
All 3 Pieces Packaged Inside 1 Polybag

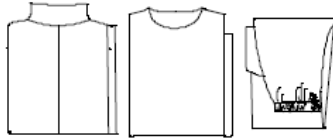

1. Multiple Piece set to be packaged into a polybag.

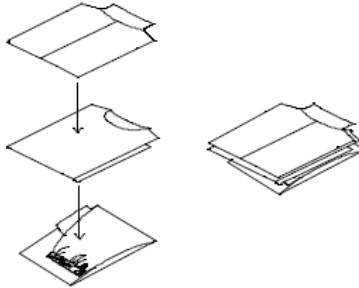

2. Layer 3 pieces together

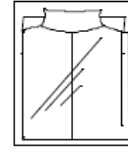

3. Place folded 3 piece set into appropriately sized polybag, seal and label with bar code.

**OPTION 2:**  
Side-By-Side Pocket Polybag

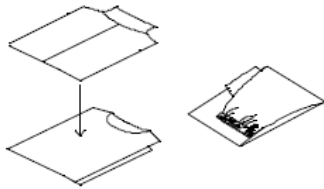

1. 3 piece set to be packaged into an envelope style polybag.

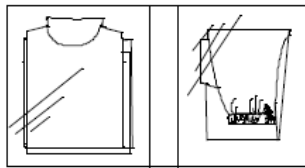

2. 2 pieces stacked on top of each other on one side of envelope, opposite side of envelope has 3rd piece, or in one poly bag

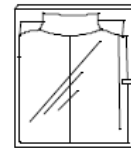

3. Fold at center and tape closed.

### 3.6.9. Packaging H – Coats without Hangers

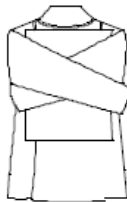

1. Lay item front side down. Place tissue on center back of coat, even with shoulders. Fold both sleeves across back of garment.



2. Place item in appropriately sized polybag. \*Short Coats (under 36") have no fold.



### 3.6.10. Packaging I – Coats/Sweaters

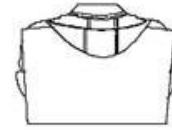

1. Lay item front side down.  
Place tissue on center back of coat, even with shoulders.  
Fold both sleeves across back of garment.
2. Fold up from bottom in thirds to a square shape.

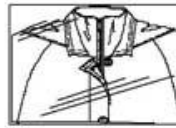

3. Place folded item in appropriately sized polybag.



### 3.6.11. DBL – Compact Double Fold Method

**NOTE:** The DBL fold has been created to replace the prior version of the N fold. The N fold was formerly used solely for garment tops. The DBL fold has been created to be a “universal” double fold for all applicable garment styles/ fabrications. When approved for use, the DBL fold indicator will be noted in the Stand-up Tag (ST) field of the QUEST pack recipe. As normally done in the past, the garment style code fold (B, C, K, etc.) will still be noted in the Pouch (P) field of the QUEST pack recipe. Below is an example of a shirt following the B fold (steps 1-3), then following the DBL fold (steps 4-6). If approved for use, the DBL fold could be used in combination with the B, C, K, D, E, F or G fold methods. As always, these fold methods will be determined during TOP/ First Piece QA.

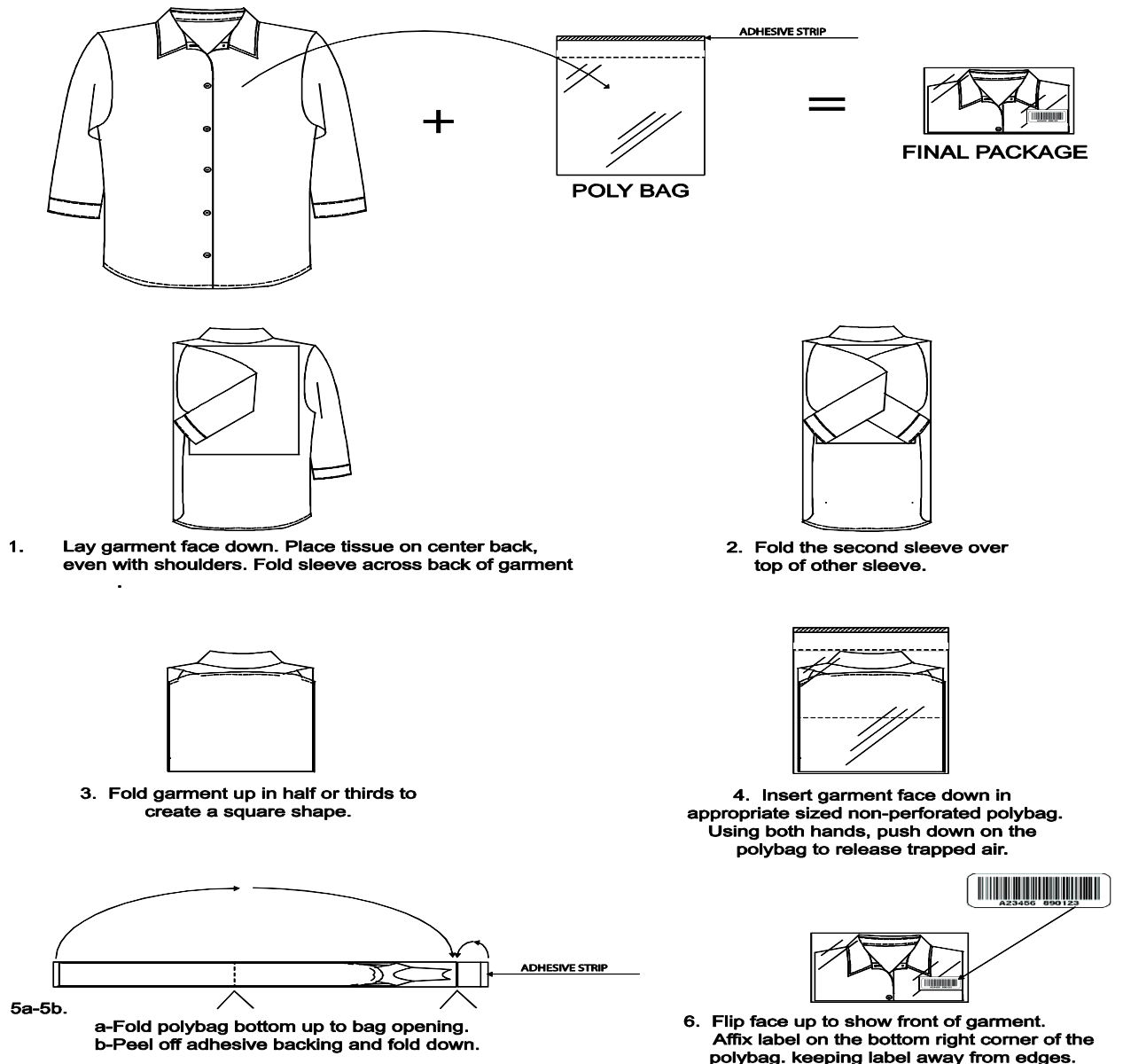



### 3.6.12. Packaging Q – Garment on Hanger

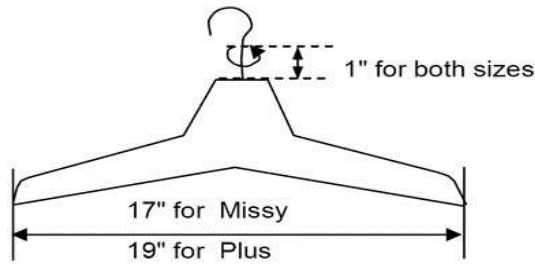

Hanger: style is as sketch, it should remove the hook on the top of hanger; the metal hook is rotatable  
size: 17" for Missy  
19" for Plus  
color: black  
The GOH Plastic Bag must be fabricated of at least 0.6 mil plastic.

#### PACKAGING GARMENT ON HANGERS

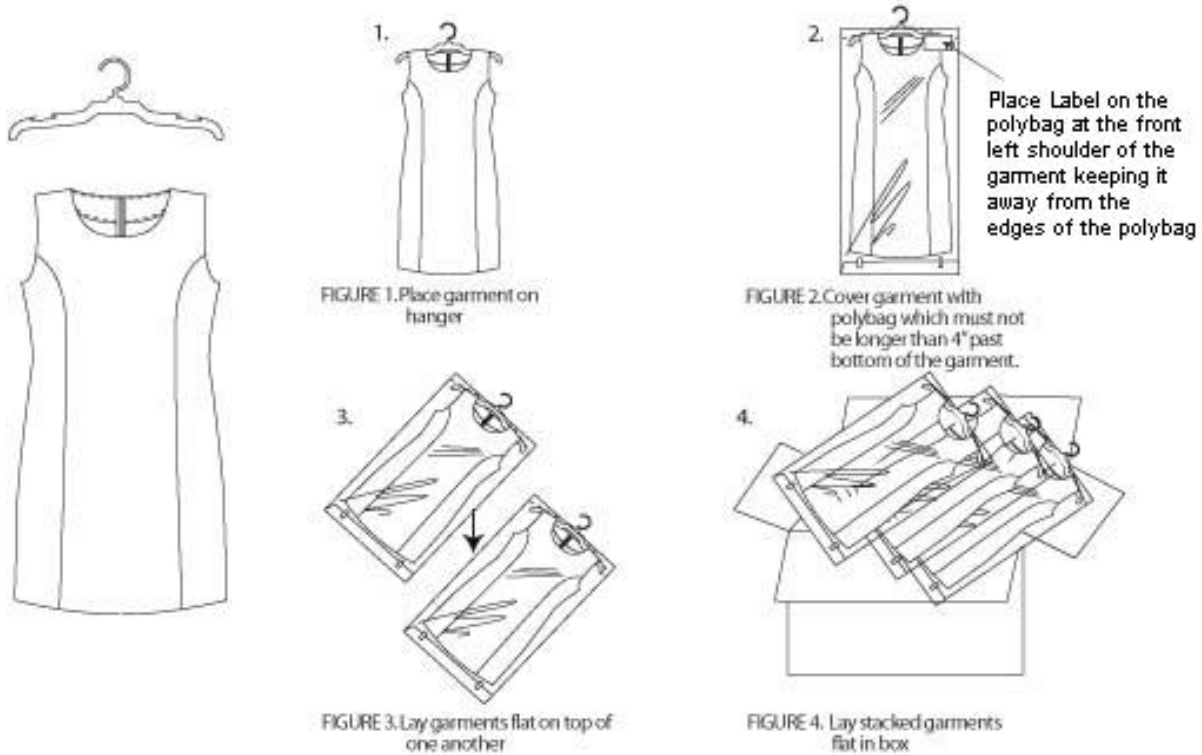

**NOTE:** Follow Sketch 2 for all faux fur coats. Do not package faux fur coats with tissue.

**NOTE:** Leather and Suede returns are to be packaged per sketch 2.

**NOTE:** All tissue paper must be Grade #1 (acid free) and at least 10lb basis weight material and must extend at least 4" beyond the shoulders of the garment. Tissue paper edges must be folded over and secured with tape so that the garment is completely concealed.



### Sketch 1 - Illustrated Packaging Guidelines – Leather and Suede Garment on Hanger, Components

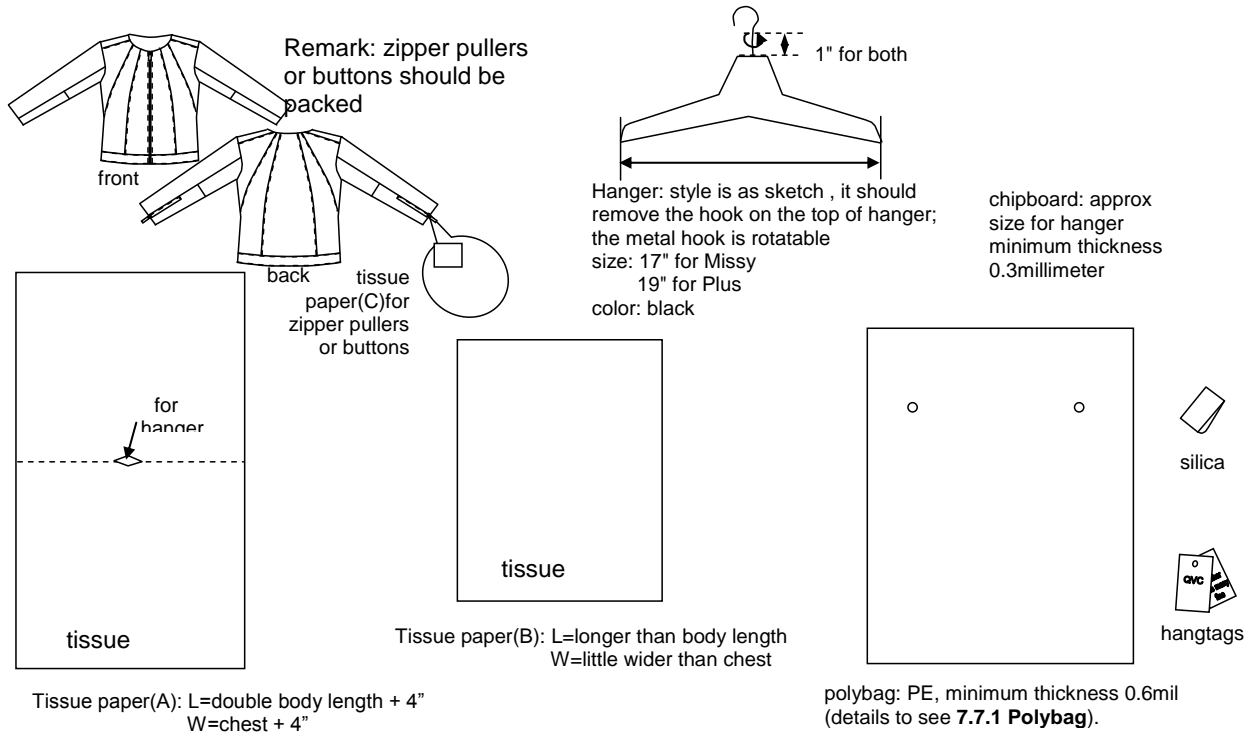

**NOTE:** All tissue paper must be Grade #1 (acid free) and at least 10lb basis weight material and must extend at least 4" beyond the shoulders of the garment. Tissue paper edges must be folded over and secured with tape so that the garment is completely concealed.





### Sketch 2 - Illustrated Packaging Guidelines –Leather and Suede Garment on Hanger

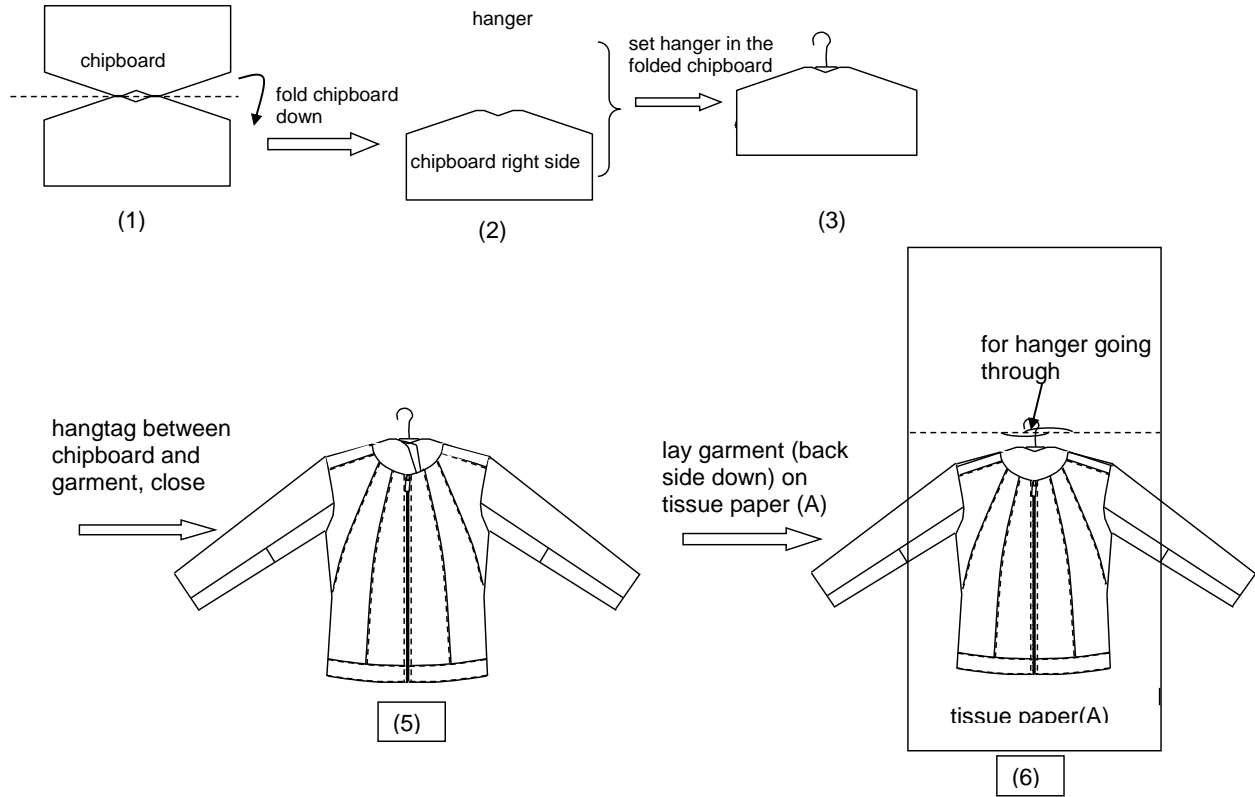



### Sketch 3 - Illustrated Packaging Guidelines – Leather and Suede Garment on Hanger

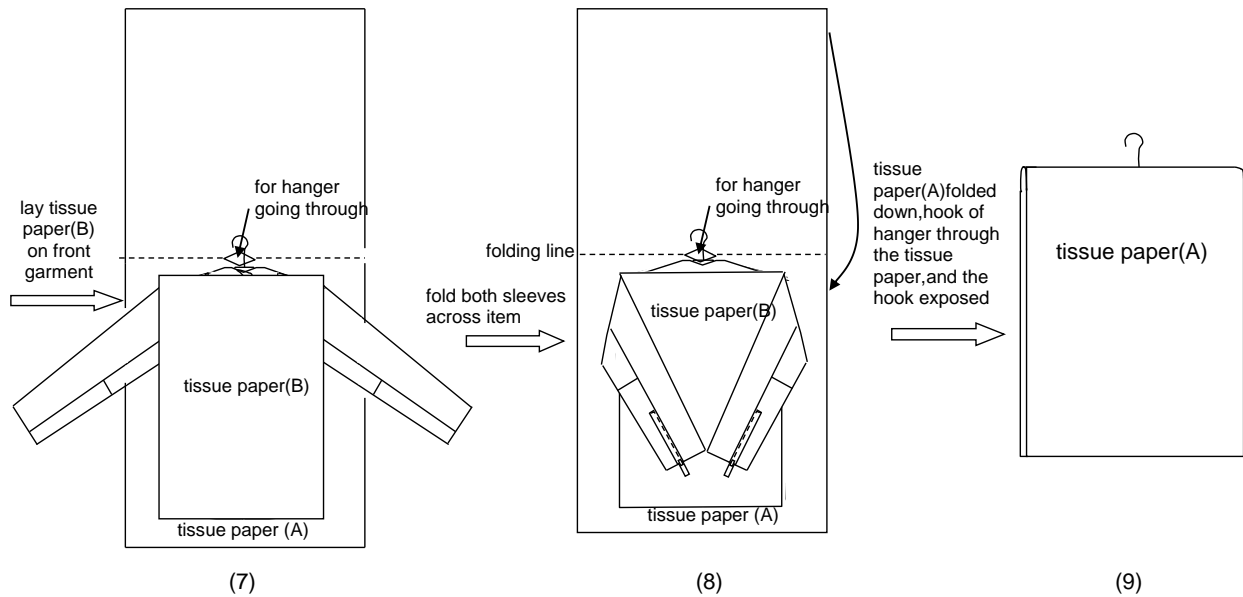

### Sketch 4 - Illustrated Packaging Guidelines – Leather and Suede Garment on Hanger

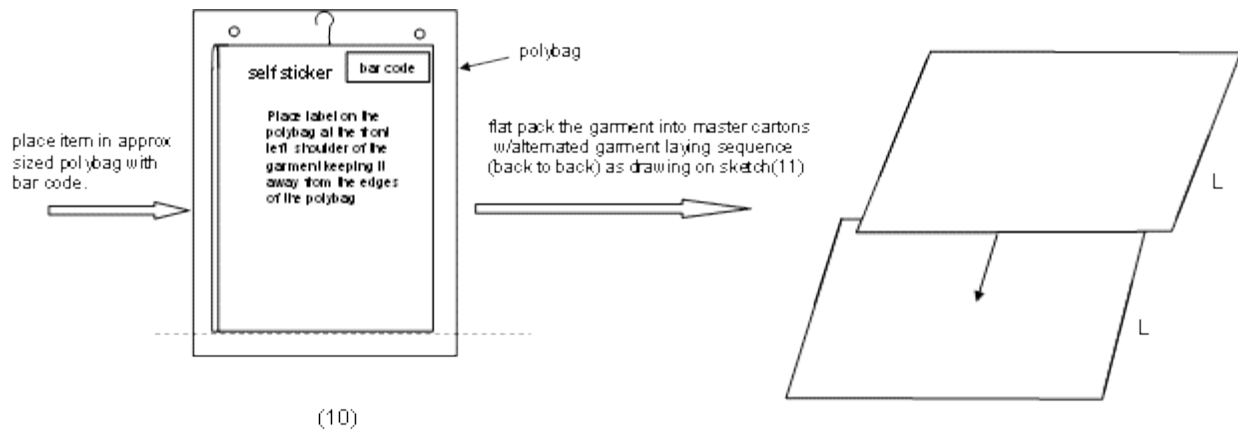



## 4. Home Textiles; Special Packaging Requirements

Home textiles are particularly at risk for tearing, soiling and becoming disheveled in transit. To ensure that home textiles are received in a clean and orderly condition, QVC has set forth the following requirements for home textile packaging.

### 4.1. Internal Packaging

Most times, because of the physical characteristics (low fragility) of the product, home textile items require little to no internal packaging. However, all home textile items must contain at least a primary package.

#### 4.1.1. Polybags

Polybag packaging must meet the following criteria:

1. Each home textile saleable unit must be packaged in a polybag. Each individual saleable unit must be packaged separately. A saleable unit with multiple pieces (i.e., set) must be packaged together in one master polybag, without taping or tying the pieces together.
2. All polybags must be new. QVC will not accept refurbished or used polybags of any kind.
3. Polybags must be clear (transparent) plastic polyethylene.
4. Polybags must have a minimum thickness of 1.5 mil.
5. Polybags must be closed securely by heat seal, tape or zipper. Tied polybags are only acceptable for rug items.
6. Polybags used to package Home Textiles may have perforated holes within the film.
  - a. QVC recommends Home Textiles made of suede, leathers, skins, etc., be packaged in polybags with perforated holes.
7. The polybag must be the appropriate size for the saleable unit. Polybags that are too large or small will be subject to rejection.
8. Polybags must be consistent (same materials, dimensions, transparency and thickness) throughout the Purchase Order.
9. All polybags must meet QVC's polybag and film specification and labeling requirements, see section [Polybag and Film Requirements and Labeling](#).

---

**NOTE:** Please note, as a general rule, it is not acceptable to vacuum pack Home Textile products. The reason not to vacuum pack is to avoid known defects such as



compression loss, wrinkling, static cling, off odors, etc., which could occur to the product during extended storage. Additionally, there are damage concerns when the packaged-product is being opened by the customer with sharp utensils such as scissors or a knife. Exceptions to the rule will be dealt with on a case-by-case basis and must have approval from the QVC merchant and the Packaging Engineer.

---

### 4.1.2. Protective Chipboard/Corrugate

All soft goods home textile merchandise require protective chipboard/corrugate cut sheet within the vendor reshipper and/or master carton packaging, see section [Protective Chipboard/Corrugate – Required for all Soft Goods Merchandise](#).

## 4.2. Inserts

Inserts or instructions must fit inside the packaging without excessive bending or folding. Any insert must receive prior approval from QVC QA during the First-Piece QA Sample Evaluation.

## 4.3. Shipping Cartons

Home textiles may be shipped in reshippers, inner cartons, and master cartons. When shipping home textiles in bulk to QVC, vendors may need to pack units in inner cartons and/or a master carton. Vendors are not required to use inner cartons; however, QVC QA may suggest inner cartons in order to further protect the saleable units. All shipping cartons for home textiles must comply with the following requirements, in addition to general strength, cushioning, and sealing standards outlined in this chapter.

When using a corrugate carton, the following criteria must be met:

1. Whenever a home textile saleable unit, and its protective polybag, comes in direct contact with the interior of the carton, the manufacturer's joint must be glued or taped only. Stapled or stitched joints are not permitted. (This will prevent or minimize apparel and protective bags from being snagged.)
2. There must be no internal or external sharp projections or edges. The use of staples or metal stitching as a means of closure is not permitted.



## 4.4. Folding

The manner in which a textile is folded and packaged impacts its appearance after going through transit. QVC will accept variances in folding; however, the vendor must always comply with the following:

1. Each unit must be folded or arranged neatly, and in a manner which is appropriate for the product type.
2. Folded home textiles must be folded with tissue paper, chipboard or corrugated cut sheet to protect the product's shape.



## 4.5. Special Requirements for Rug Packaging

Most rolled carpeting is considered a “soft” pack by the small parcel shippers such as UPS (United Parcel Service). Carpeting rolls are themselves soft and yielding, and when wrapped in paper or plastics remain subject to punctures and bending.

The small parcel shippers handle the “soft” pack parcel in a separate processing system from the conveyable boxes. Since some carpeting is considered large and heavy, they are sometimes classed as an “incompatible” in the standard shipping system, and are forced to travel with many hazards such as bare metal, motor parts and other non-standard packages. This procedure increases the chances that the outer protective packaging will be punctured or torn.

### 4.5.1. Package Components/Carpet Roll

It is QVC’s goal to reduce the damages to carpeting which may occur during shipping both to our Distribution Center and to our customers.

These packaging methods will not only assist in protecting the product from damage but will also help within the handling environment to reduce the occurrence of handling damage, package failure, and loss of shipping information.

The following guidelines are required for rugs greater than 4ft (in any direction) when rolled:

1. QVC recommends that the carpeting be wound onto a core with the actual core material extending beyond the width of the carpet by 0.5” (1.25 cm) on each end. This will aid in protecting the carpet from being soiled because the tube will be what comes in contact with any surface abrasion. The minimum core thickness of 0.1875” (0.5 cm) will reduce bending damage and add support from within the package during handling.
2. Rugs that are 108” long when rolled cannot have the core rod sticking out 0.5” on either end. This is because the max dimensions will exceed the limitation for small parcel shipment, see section [Rug Shipping Dimensions](#).
3. The carpet should be tightly rolled. If the carpet is unable to support its own weight, and folds when held in the middle, it shall be tightly rolled onto a rigid core, which helps keep the carpeting from crushing, creasing, stretching, or bending.
4. The carpet shall then be secured by tying in three locations. One tie shall be in the middle of the carpet, and the remaining ties shall be placed approximately 12” (30 cm) from each end.
5. The carpet shall be rolled in such a manner as to be even on both ends. An unevenly rolled carpet will not be accepted as it increases



the shipping dimensions which in turn increases the shipping costs, as well as increases the chances of damages during shipment.

#### 4.5.2. Wrapping

To further protect the rug during transit it is vital that the polybag packaging is sufficient to keep the product clean and free from moisture. The following guidelines are required for rug packaging.

1. Each carpet shall first be placed in a clear (transparent) inner polybag which is sealed at both ends. This inner polybag will help waterproof the packaging thus eliminating potential damage.
2. Once the inner bag is applied each carpet shall then be placed in an outer opaque polybag that must meet one of the following specifications:
  - Polyethylene 6 mil minimum
  - Low Density Polyethylene 4 mil minimum
  - Linear Low Density Polyethylene 3.5 mil minimum
  - Tyvek® or similar product 24 pound (11 kg)

---

**NOTE:** Tyvek® is a polyolefin plastic bag that offers great strength and is an opaque white.

---

3. The outer opaque packaging shall not have excess material or a blousing effect that can be used for a handle during shipping. The excess material shall be folded over and secured using 2” (5 cm) plastic pressure sensitive tape along the length of the roll.
4. The outer package shall have a hard smooth surface which will help reduce the mobility within the packaging as well as provide a secure surface for mailing labels.

#### 4.5.3. Closure of Wrapping

There are many methods of closure including stapling, sewing, stitching, taping, wire tie and “hog” ring clamp. Most will work effective in the “soft” pack shipping system.

QVC requires one of the three styles when closing the polybag:

1. Wire Tie Closures – The tie must be capable of being twisted around the neck of the bag at least one full circumference. The remaining wire is twisted around to secure the complete closure. The excess plastic material or “bloom” is to be cut off and the remainder taped down with 2” (5 cm) pressure sensitive tape.



## QVC QA Packaging & Labeling Guidelines – All Commodities

2. Stitching, Stapling or Sewn Closures – There shall be a minimum of 2 threads or staples per inch. There shall be no excess material or bloom when securing the package ends using this method.
3. Hog Ring Closures – The hog ring closure shall be of a heavy gauge steel wire which is wrapped securely around the bag closure and overlaps itself.

### 4.5.4. Rug Shipping Dimensions

During First-Piece QA Evaluation, QVC QA will measure the First-Piece QA Sample to determine the shipping dimension for the selling unit. This dimension is then used by the QVC Supply Chain Department to determine how the selling unit will be shipped to the QVC customer.

The QVC Supply Chain Department determines the shipping method for the selling unit based on the policies of the small parcel courier. The following are the basic shipping classes used by QVC and the small parcel couriers for US Domestic Transportation:

1. If the carpet's length + girth is greater than 130" (3.3 m), but less than or equal to 165" (4.19 m), it may be shipped with a small parcel courier. Carpets within this size range are classified as a "Large Package." A Large Package Surcharge will apply, and the package is subject to a minimum billable weight of 90 lbs.
2. If the carpet's length + girth is greater than 165" (4.19 m), it may not be shipped with a small parcel courier. Carpeting above this size can be shipped through a Less-Than-Truckload Carrier. Less-Than-Truckload delivery services are not commonly available for packages shipped from QVC Distribution Centers. Shipping rates for these carpets are considerably higher than those charged for the above shipping classes.
3. If when rolled, any dimension exceeds 108", the rug may not ship with a small parcel courier. Carpeting with a dimension greater than 108" must be shipped through a Less-Than-Truckload Carrier. Less-Than-Truckload delivery services are not commonly available for packages shipped from QVC Distribution Centers. Shipping rates for these carpets are considerably higher than those charged for the above shipping classes.
4. For additional packaging surcharges see section [Additional Shipping Charges](#).

Length + Girth for all packages is calculated as follows: [Length + (2 x height) + (2 x width)]. For rolled Rugs, height and width are the outermost dimensions of the packaged rug when it is at rest. The circumference is not used in this calculation.





## QVC QA Packaging & Labeling Guidelines – All Commodities

Excess packaging material (protruding from the ends of a bagged rug) contributes to the length of the package, and should be included in all calculations.

Due to the different shipping classes and rates, the First-Piece QA Sample must accurately represent the dimensions of the selling units within the final production lot. If during the Finished-Product Audit, it is determined that the shipping dimensions do not fall within the same shipping class as the First-Piece QA Sample, QVC reserves the right to hold or reject such product.



## 5. Hardgoods, Beauty, & Cosmetics Special Packaging Requirements

### 5.1. General

This section addresses the ability of individual packaged-product to survive transit and handling, from the time of receipt (in good condition) at the QVC Distribution Center (DC), until the order reaches the customer. This section defines the packaged-product tests which all products must pass. Information is also included on packaging and labeling requirements for specific types of products.

Throughout this section, the term Packaged-Product refers to the saleable item in the packaging which will be used to ship it to the QVC Customer.

The Manager of Packaging and/or the Director of Quality Assurance, QVC Corporate Quality Assurance Department, must approve any deviations or exceptions to these requirements.

### 5.2. First-Piece QA Sample Preparation and Submittals

To ensure testing is performed with the product in a near as perfect condition as possible, packaged-products submitted to QVC as First-Piece QA samples should be over-packaged for shipment to QVC. Packaged-products which have already been subjected to the rigors of transportation through shipment to QVC cannot be assumed to represent standard conditions. Simply applying a shipping label to the sample may not be appropriate. We strongly suggest the following:

1. Make certain that the product itself is packaged exactly as it will be shipped to QVC's Distribution Center (Required).
2. Over-pack the item and its packaging in a manner which will protect the sample during transit to QVC (Preferred).
  - (1) Mark the over pack shipping carton with words such as "QA Sample Inside" (Required, if using overbox to ship sample during 1st piece testing/evaluation).
3. Tamper-evident security tape is recommended, particularly for packages originating outside the USA (Preferred).

### 5.3. Vendor Reshippers

Based on the product type and/or size, QVC may require the vendor to overbox the product in a reshippable container (a reshipper).

When a vendor reshipper is required, the following criteria must be met:



## QVC QA Packaging & Labeling Guidelines – All Commodities

1. A reshipper is a sturdy outer package which QVC can ship directly to our customers with minimum processing and handling. A reshipper may be the primary product packaging, or an overbox.
2. A suitable reshipper protects and cushions merchandise within a heavy unbleached brown kraft corrugate container.
3. A reshipper should have minimal carton markings and graphics, be securely sealed, and meet package testing requirements.
4. A reshipper must be at least a B or C flute container. A reshipper which is made with an E-flute (approximately 1.5mm thickness) corrugate is not acceptable.
5. Lastly, please see section [Automation Ready Vendor Reshippers](#), for further details related to the QVC DC fulfillment process.

### 5.3.1. Packaging for TSV and High Volume PO's

QVC requires that all Today's Special Value ("TSV's") items and other high unit volume products be packaged in reshippers. A high unit volume product is defined as an item which will have 5,000 or more items shipped to QVC within a year's time.

### 5.3.2. High Graphics on Packaged-Products

In brick-and-mortar retail scenarios, product packaging with eye-catching graphics provides advertising value and enhances product image. This is not necessary or in most cases desirable for a shipping container. Products which are of high value, toys, or items likely to be gifts which have high graphics and/or carton markings which identify the package contents must be over-boxed by the vendor in plain kraft corrugated containers.

QVC requires reshippers be made of unbleached brown kraft paper (non white) corrugate. QVC shipping labels do not properly adhere to glossy retail packaging thus these high graphic glossy boxes are not acceptable for use.

## 5.4. Liquids Packaging

QVC has special requirements for liquids to ensure such products are packaged adequately to survive handling and transit without leakage, and to ensure that minimum container labeling and package marking requirements are satisfied. QVC has zero-tolerance for leakage, especially for Hazardous Materials ("HazMats"). "Leakers" represent a service failure to our customers, and leakage can and will damage other products in the distribution stream.

The requirements outlined below apply to all liquid products, including aerosols, sold by QVC which are packaged in glass, metal or plastic



containers. These requirements may be applied to powders or semi-liquids at the discretion of QVC's Quality Assurance Departments. These requirements address the packaging and labeling of liquids; they do not address the ability of the liquids to perform their intended function(s).

### 5.4.1. Liquid; Special Packaging Requirements

All liquid products must meet the following criteria:

1. The packaging for liquids must be designed to contain and protect the contents from damage and leakage throughout the entire distribution system. Care must be taken to ensure that glass, metal or plastic containers are immobilized and cushioned within the corrugated shipping container. It is recommended that the top/closure be protected with cushioning material.
2. There are hundreds, if not thousands, of materials, and combinations thereof, available to develop a closure system. The vendor is solely responsible for the selection of the appropriate cap liner (gasket) and inner seal so as to pass all the tests and specifications. Cap liners are generally required to minimize or resist torque back-off or decay. Except for high-quality induction seals, inner seals generally make only a slight contribution to a leak-proof system (although inner seals may satisfy requirements for tamper-evidence).
3. QVC may require, at its discretion, a letter certifying compatibility of the chemical contents and the container, including closure system.
4. ALL liquids containing 8 fluid ounces (237 ml) and greater per plastic polymer container **MUST** have a high-quality induction seal.
  - (1) Induction seal- Non-contact method of heating a metallic disk to hermetically seal the top of a plastic container/bottle. The heat sealing process takes place after the container has been filled and capped to its proper torque.
5. Bottle/closure systems not allowing for an induction seal because of a locking or concaved (into the neck of the bottle) closure must pass ASTM D3078 Standard Test method for Determination of Leaks in Flexible Packaging by Bubble Emission.
  - (1) The ASTM D3078 vacuum leak test must be done via a third party test lab. See ASTM.org to search for a test lab.
  - (2) QVC Protocol
    - (a) Medium Vacuum – 18.5 +/- 0.5Hg for 1 minute
    - (b) High Vacuum – 24.5 +/- 0.5Hg for 1 minute



## QVC QA Packaging & Labeling Guidelines – All Commodities

- (3) When completed, the ASTM D3078 vacuum leak test report must be submitted to [QVCQAHardGoods@QVC.COM](mailto:QVCQAHardGoods@QVC.COM) alongside the QA physical sample.
6. ALL liquids containing 8 fluid ounces (237 ml) and greater must be packaged in a vendor reshipper.
7. Liquids intended to be dispensed with a spray nozzle MUST have the nozzle packaged separately from bottle within the corrugate container so an induction seal can be implemented on the land of the bottle.
8. Glass containers/bottles are not required to have an induction seal for any size (fluid volume). QVC QA discourages the use of glass containers/bottles as they are more likely to show signs of leakage without the proper sealing.
9. The vendor must include the Material Safety Data Sheet(s) along with all submitted First-Piece QA samples. Refer to General QVC Sheets, Hazardous and Toxic Chemicals, Volatile Organic Compounds, and Hazardous Material.

---

QVC-QA will reject any product which shows any evidence of leakage during package testing.

---

### 5.5. Package Testing

The International Safe Transit Association (“ISTA”, <http://www.ista.org>) has developed a variety of internationally recognized package test protocols which predict the ability of a packaged-product to survive transit and handling. Many of these tests are “challenge tests” in that they challenge a packaged-product to withstand a series of pre-determined hazards.

QVC is equipped with package testing equipment which meets ISTA and ASTM requirements, and tests packaged-products utilizing the ISTA 1A and 3A protocols.

QVC requires that most packaged-products pass a variation of the ISTA Integrity Test Procedure 1A, this test does not purport to simulate the distribution environment. Rather, this test method simply tests the relative “robustness” of the packaged product.

QVC ships almost all of its products using small parcel distribution systems. A package test method that more closely represents the nature and intensities of the hazards typically found in the distribution or small parcel shipping environment is ISTA Procedure 3A: Packaged-Products for Parcel Delivery System Shipments 70Kg (150 Lb) or Less (standard, small, flat or elongated).

QVC will require some products to be tested using ISTA Test Method 3A. ISTA 3A testing must be done via third party test lab, see [ISTA.org](http://ISTA.org) to search for an approved test lab.



### 5.5.1. QVC ISTA 1A Package Testing

**NOTE:** QVC QA does all ISTA 1A testing in-house free of charge.

ISTA 1A defines testing requirements for Packaged-Products up to 150 pounds.

ISTA Procedure 1A entails subjecting a packaged-product first to vibration testing, and then to drop/impact testing. ISTA 1A specifies a 10-point drop test. QVC performs one additional corner drop. This modified procedure is called QVC ISTA PROCEDURE 1A.

QVC QA strongly encourages performing a preliminary drop test on at least 3 samples before submitting a 1<sup>st</sup> piece QA sample. If the 3 samples tested appear to be non-damaged (no chips, crack, still functional, etc) and there is not excessive packaging damage, then it is encouraged that the vendor submit the 1<sup>st</sup> piece QA sample. A preliminary drop test will provide greater confidence that the packaged-product will successfully pass during the 1<sup>st</sup> piece QA sample submission.

#### 5.5.1.1. QVC’s ISTA 1A Test Procedure

- Pre-Existing Damage

Examine the product and its packaging for any pre-existing damage.

- Vibration Test

Subject the packaged-product to 14,200 vibratory impacts, with a vibration amplitude (distance) such that the packaged-product momentarily leaves the surface of the vibration table, by 1/16” (0.16 cm). Depending on the weight of the product, the vibration frequency will be in the range of 150 to 300 Cycles Per Minute (CPM) (2.5 to 5 Hz), with test duration of 47 to 90 minutes.

- Drop/Impact Test

Weigh the Packaged-Product (with the product inside) to determine the appropriate drop height:

Package Weight	Drop Height
Up to 20.9 pounds (9.5 kg)	30 inches (76 cm)
21.0 to 40.9 pounds (18.6 kg)	24 inches (61 cm)
41.0 to 60.9 pounds (27.7 kg)	18 inches (46 cm)
61.0 to 100 pounds (45.5 kg)	12 inches (31 cm)

Number of Drops and Orientation: Drop the Packaged-Product eleven (11) times from the appropriate height on a bare, hard (steel plate or concrete) floor, in the following order:



## QVC QA Packaging & Labeling Guidelines – All Commodities

- 1st drop - corner of packaged-products manufacturer's joint
- 2nd – 4th drop - 3 edges radiating from manufacturer's joint in 1st drop in the following order:
  - Shortest edge radiating from corner tested
  - Next longest edge radiating from corner tested
  - Longest edge radiating from corner tested
- 5th drop - on the corner diagonally farthest from the 1st drop corner
- 6th drop & 7th drop – one of the smallest faces of the container then the opposite small face
- 8th drop & 9th drop – one of the medium faces of the container then the opposite medium face
- 10th drop & 11th drop – one of the largest faces of the container then the opposite large face



# QVC QA Packaging & Labeling Guidelines – All Commodities



**DROP 1**

Most Fragile Corner  
(Manufacturer's Joint)



**DROP 2**

Shortest Edge From DROP 1  
Corner



**DROP 3**

Medium Edge From DROP 1  
Corner



**DROP 4**

Longest Edge From  
DROP 1 Corner

Drop 1 Corner



**DROP 5**

Farthest Corner From  
DROP 1 Corner



**DROP 6**

Smallest Flat Face



**DROP 7**

Opposite Smallest Flat  
Face



**DROP 8**

Medium Flat Face



**DROP 9**

Opposite Medium Flat Face



**DROP 10**

Largest Flat Face



**DROP 11**

Opposite Largest Flat Face





- Post-Product Inspection

**NOTE:** Even if the product is undamaged, if QVC believes there is excessive packaging damage, improved packaging will be required.

After performing the drop tests, examine the product and its packaging for defects. The packaging must be intact.

Inspect the product for any physical or functional damage. This inspection includes checking for the ability of the item to be assembled and its overall functionality. If the product is found to be damaged in any way or does not function properly, the packaging must be improved and retested.

### 5.5.2. ISTA 3A Package Testing

**NOTE:** ISTA 3A testing must be done via third party test lab, see [ISTA.org](http://ISTA.org) to search for an approved test lab.

ISTA 3A defines testing requirements for Packaged-Products up to 150 pounds or less when prepared for shipment via a parcel delivery carrier.

ISTA Procedure 3A entails subjecting a packaged-product to various vibration testing and a 17 point drop test.

When testing per ISTA 3A only one saleable unit is required to be sent to the third party test lab. Inner and master carton packaging does not require ISTA 3A testing.

#### 5.5.2.1. Products Requiring ISTA 3A Testing (Effective September, 2011)

**NOTE:** At the sole discretion of QVC-QA, ISTA 3A Testing may be required for any specific product.

**Accessories – Jewelry**

Jewelry Storage

**Bath**

Bathroom Storage (glass, ceramic, terracotta, wood)

**Candles & Scents - Dept**

Flameless Candles (glass, ceramic, terracotta)

Real Flame Candles (glass, ceramic, terracotta)

**Collectibles**

Bells (glass, ceramic, terracotta)

Collector Plates (glass, ceramic, terracotta)

Commemoratives (reorg) (glass, ceramic, terracotta)

Dolls – Collectibles (glass, ceramic, terracotta)

Figurines & Sculpture (glass, ceramic, terracotta)

Music Boxes (glass, ceramic, terracotta)

Trinket Boxes (glass, ceramic, terracotta)

Villages (glass, ceramic, terracotta)

Water Globes (glass, ceramic, terracotta)

**Computers**



Desktop PCs  
Monitors  
Netbooks  
Notebook Computers  
Speakers - computers

**Consumer Electronics**

All-In-One Printers  
Answering Machines  
CBs & Scanners  
Digital Camcorders  
Digital Photo Frames & Viewers  
DVD - Portable  
DVD- Blue Ray  
DVD/VCR Combos  
EReference  
Home Theater Systems  
Karaoke  
Lenses - Camera  
Musical Instruments - Electronics  
Nostalgia Audio

**Consumer Electronics (cont.)**

Shredders  
Telescopes

**Cookware and Bakeware**

Accessories – Cookware (glass, ceramic, terracotta)  
Bakers, Casseroles, Etc. (glass, ceramic, terracotta)  
Dutch Ovens (glass, ceramic, terracotta)  
Kettles (glass, ceramic, terracotta)  
More Bakeware (glass, ceramic, terracotta)  
Roasting Pans – Cookware (glass, ceramic, terracotta)  
Sauce Pans – Cookware (glass, ceramic, terracotta)

**Decorative Accents**

Baskets  
Clocks (glass, ceramic, terracotta)  
Decorative Botanicals (glass, ceramic, terracotta)  
Decorative Boxes & Trunks (glass, ceramic, terracotta)  
Indoor Fountains  
Mirrors  
Picture Frames  
Stained Glass Panels, Etc.

Wall Décor (glass, ceramic, terracotta)

**Dinnerware**

Bar Accessories (glass, ceramic, terracotta)  
Beverageware (glass, ceramic, terracotta)  
Bowls – Dinnerware (glass, ceramic, terracotta)  
Butter Dishes - Serving Pieces (glass, ceramic, terracotta)  
Coffee & Tea Pots - Serving Pieces (glass, ceramic, terracotta)  
Cups & Saucers (glass, ceramic, terracotta)  
Dessert & Salad Plates (glass, ceramic, terracotta)  
Pitchers - Serving Pieces (glass, ceramic, terracotta)  
Place Settings – Dinnerware (glass, ceramic, terracotta)

**Dinnerware (cont.)**

Serving Baskets - Serving Pieces (glass, ceramic, terracotta)  
Serving Bowls - Serving Pieces (glass, ceramic, terracotta)  
Serving Plates & Platters (glass, ceramic, terracotta)  
Sets – Dinnerware (glass, ceramic, terracotta)  
Sets - Serving Pieces (glass, ceramic, terracotta)  
Specialty Pieces – Dinnerware (glass, ceramic, terracotta)  
Sugar Bowls & Creamers (glass, ceramic, terracotta)  
Tabletop Carafes - Serving Pieces (glass, ceramic, terracotta)  
Trays - Serving Pieces (glass, ceramic, terracotta)  
Tureens (glass, ceramic, terracotta)

**Furniture**

Accessories - Furniture  
Beds, Etc.  
Cabinets & Chests  
Jewelry Armoires, Etc.  
Kid's Furniture (Children's?)  
Media Furniture  
Office Furniture  
Quilt Racks & Blanket Stands



Seating  
Tables

**Health and Fitness**

Camping & Hiking Equipment  
Fitness Equipment  
Magnifiers & Reading Glasses (glass)

**Holiday & Party Shop**

Christmas Decorations (glass, ceramic, terracotta)  
Easter Decorations (glass, ceramic, terracotta)  
Halloween Decorations (glass, ceramic, terracotta)  
Harvest Decorations (glass, ceramic, terracotta)

**Home Environment**

Air Cleaners  
Fans & Ventilators  
Fireplaces - HI Path

**Home Environment (cont.)**

Heaters & A/C  
Humidifiers & Dehumidifiers

**Kitchen Electrics**

Blenders  
Breadmakers  
Coffee Makers  
Convection Ovens  
Deep Fryers  
Espresso Makers & Cappuccino Makers  
Food Prep  
Ice Cream Makers & Ice Shavers  
Indoor Grills  
Juicers  
Microwave Ovens (post)  
Pots & Pans – Electric (glass, ceramic, terracotta)  
Pressure Cookers – Electric (glass, ceramic, terracotta)  
Roasters & Rotisseries (glass, ceramic, terracotta)

Slow Cookers (glass, ceramic, terracotta)  
Stand Mixers  
Steamers & Rice Cookers - Kitchen  
Electrics  
Tea Makers, Etc.  
Toaster Ovens & Broilers  
Toasters  
Waffle Makers, Etc.  
Warming Trays, Etc.

**Kitchen Tools Accessories and Flatware**

Colanders & Strainers  
Electric Knives  
Mixing Bowls (glass, ceramic, terracotta)  
Slicers & Graters & Choppers

**Laundry & Closet**

Irons & Clothes Steamers

**Lighting Department**

Indoor Lighting

**Outdoor Living**

Bird Feeders, Etc.  
Coolers & Bottles  
Fencing  
Lawn Decorations (glass, ceramic, terracotta)

**Outdoor Living (cont.)**

Outdoor Furniture (glass, ceramic, terracotta)  
Picnic & Beach Gear  
Water Gardens & Fountains

**Storage & Organization**

Cookie Jars & Canisters (glass, ceramic, terracotta)  
Kitchen Carts & Islands

**Televisions**

HD Flat Panel TVs



### 5.5.2.2. QVC's ISTA 3A Protocol

When testing per ISTA 3A, the following criteria must be met:

- Atmospheric Preconditioning

One test specimen will be conditioned to the current ambient lab conditions for 24 hours.

- Atmospheric Conditioning

Packaged products are subjected to tropical temperatures of 100°F and 85% RH for 24 hours. Wood and wood-like products will then be conditioned to desert temperatures of 140°F and 30% RH for 12 hours.

- Shock (1)

Packages are dropped 9 times from various heights and orientations. (Drop height is determined by the weight of the package.)

- Vibration

Random with and without a top load. (Top loads are determined using the formula given in the current year ISTA Resource Book under 3A testing)

- Shock (2)

Packages are dropped 8 times from various heights and orientations. (Drop height is determined by the weight of the package. The final drop is made onto a "hazard")

### 5.5.2.3. Third-Party Package Testing Process

1. Design an appropriate package that will protect the product and withstand the rigors of the small parcel distribution environment.
2. Test the saleable unit packaged-product at an ISTA-certified test lab. As needed, re-design and re-test until the package-product passes transit testing. An ISTA certified test lab may be found by accessing the ISTA web site at <http://www.ista.org/Login/labsearch.php>.
  - (1) Package test only the saleable unit packaging
  - (2) Inner and master carton packaging do not require ISTA 3A testing.
3. Make certain that the selected test lab understands QVC package testing requirements.
  - (1) The vendor is authorized to send a copy of this chapter directly to the test lab.
4. After performing the packaging test, all individual units must be examined carefully for defects. This inspection must include appearance, functionality, and any other factor which would affect the expected use of the product.



## QVC QA Packaging & Labeling Guidelines – All Commodities

5. Once the test is successfully completed, the vendor must forward a copy of the test report along with the First-Piece QA sample to QVC QA.
  - (1) Electronic copies of the test report are required.
  - (2) Please send an electronic version of the test report to [QVCQAHardGoods@QVC.COM](mailto:QVCQAHardGoods@QVC.COM)
  - (3) Once received, QVC QA will validate the test report against the physical sample (i.e. weight, dimensions, internal packaging).
6. Once final approval is given, the vendor must establish procedures to pack the product in the designed packaging, and to ensure the product is packaged the same way each time. Periodically review and monitor this procedure to ensure compliance.

### 5.5.2.4. Third-Party Test Labs

Approved Package Testing Labs in China:

---

**NOTE:** The Vendor may obtain electronic copies of these forms by contacting the labs at the addresses shown on the sample forms.

---



<http://www.bureauveritas.com>

Bureau Veritas Consumer Products Services Division Laboratories  
Unit 406, Vanta Industrial Centre  
21-33 Tai Lin Pai Road, Kwai Chung, N.T., Hong Kong  
Phone: 852-2418-1222 Fax: 852-2401-0378

Bureau Veritas Hong Kong Limited  
Pacific Trade Centre, 1st Floor  
2 Kai Hing Road, Kowloon, Hong Kong  
Phone: 852-2331-0888 Fax: 852-2331-0889  
Sample Pick-up: 852-2331-0333  
Contact: Raymond Lam (testing)  
Email: [bvcp\\_sales@hk.bureauveritas.com](mailto:bvcp_sales@hk.bureauveritas.com)

Bureau Veritas Hong Kong Limited  
4th Floor, B Bulding, Min Li Da Industrial Building  
Honghualing Industrial Park, Liu Xian Road  
Xili, Nanshan District  
SHENZHEN 518955, Chna



## QVC QA Packaging & Labeling Guidelines – All Commodities

Phone: 86-755-86000151 Fax: 86-755-8600157  
Email: [bvcps\\_szinfo@cn.bureauveritas.com](mailto:bvcps_szinfo@cn.bureauveritas.com)



<http://www.intertek-labtest.com/>

{Testing Laboratory}  
Intertek Testing Services Shenzhen Ltd.  
7/F., Shekou Technology Main Building,  
Industrial 7th Road, Shekou, Shenzhen 518067, China  
Phone: (86-755) 2683 7000 Fax: (86-755) 2683 7118/9  
Email: Cicy Tao ([cicy.tao@intertek.com](mailto:cicy.tao@intertek.com)) / Elaine Ye  
([elaine.ye@intertek.com](mailto:elaine.ye@intertek.com)) / Gracie Wang ([gracie.wang@intertek.com](mailto:gracie.wang@intertek.com))

{For Inspection, Audit, & CSR}  
Intertek Testing Services Shenzhen Ltd.  
5/F, M-Space, Bldg. A, Nanhai Ave. South, Shekou  
Phone: (86-755)2686 1668/2602 0830 Fax: (86-755) 2667 6688/2602 0888  
Email: [labtest.shenzhen@intertek.com](mailto:labtest.shenzhen@intertek.com)

### 5.5.3. QVC “Small Bag” Package Testing

To more closely resemble the small parcel shipping environment small packaged-products will now be subject to “small bag” package testing. A small packaged-product is defined by meeting the following criteria:

- Volume is less than 13,000 cm cubed (800 in cubed), **and**
- Longest dimension is 350 mm (14 in) or less, **and**
- Weight is 4.5 kg (10 lbs.) or less

In the transportation world small packages are commonly consolidated together into a large nylon tote bag. These large tote bags measure approximately 39”x27” and can weigh as much as 30-40 lbs. Carriers consolidate packages together for ease of transportation and to prevent parcels from getting lost while traveling through the distribution channels. QVC’s “small bag” package testing is a hybrid of ISTA 1A and 3A test protocols. Like the ISTA 1A test, QVC will conduct the “small’s bag” package testing during First Piece QA free of charge. Packages subject to the “small bag” package test will be required to pass the following protocol:

- A package is first marked for testing
  - First, the nylon consolidation tote bag is labeled.



## Consolidation Bag for Small

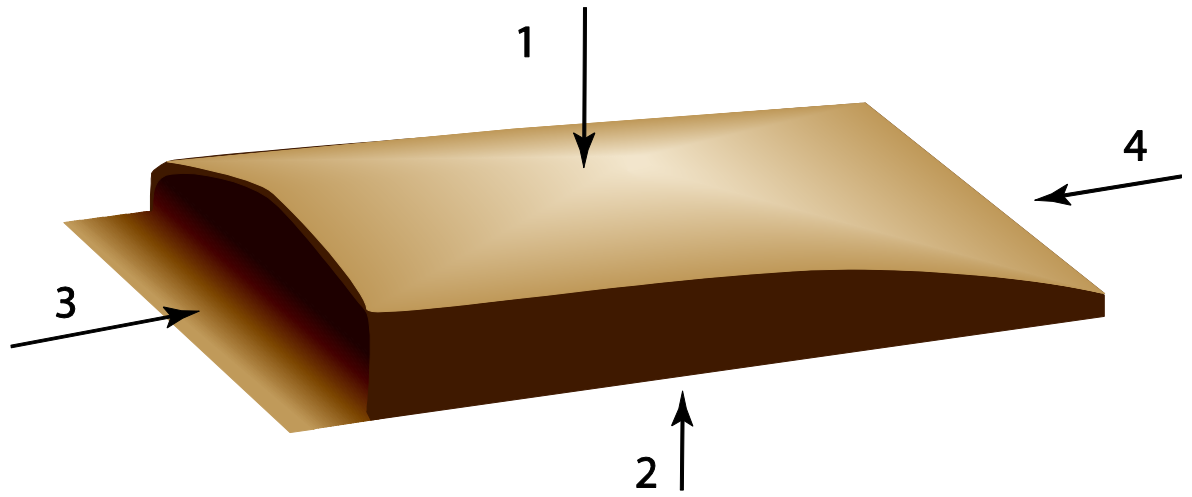

- Next, the package is labeled as a two-dimensional express envelope/mailer or a standard square package.

## Two-Dimensional Express Envelope or Mailer

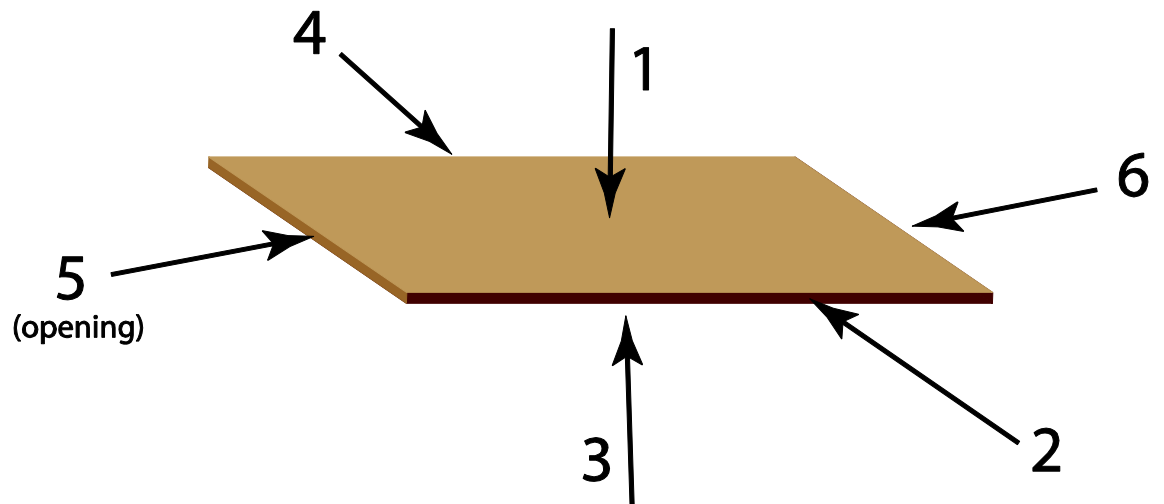



# Standard

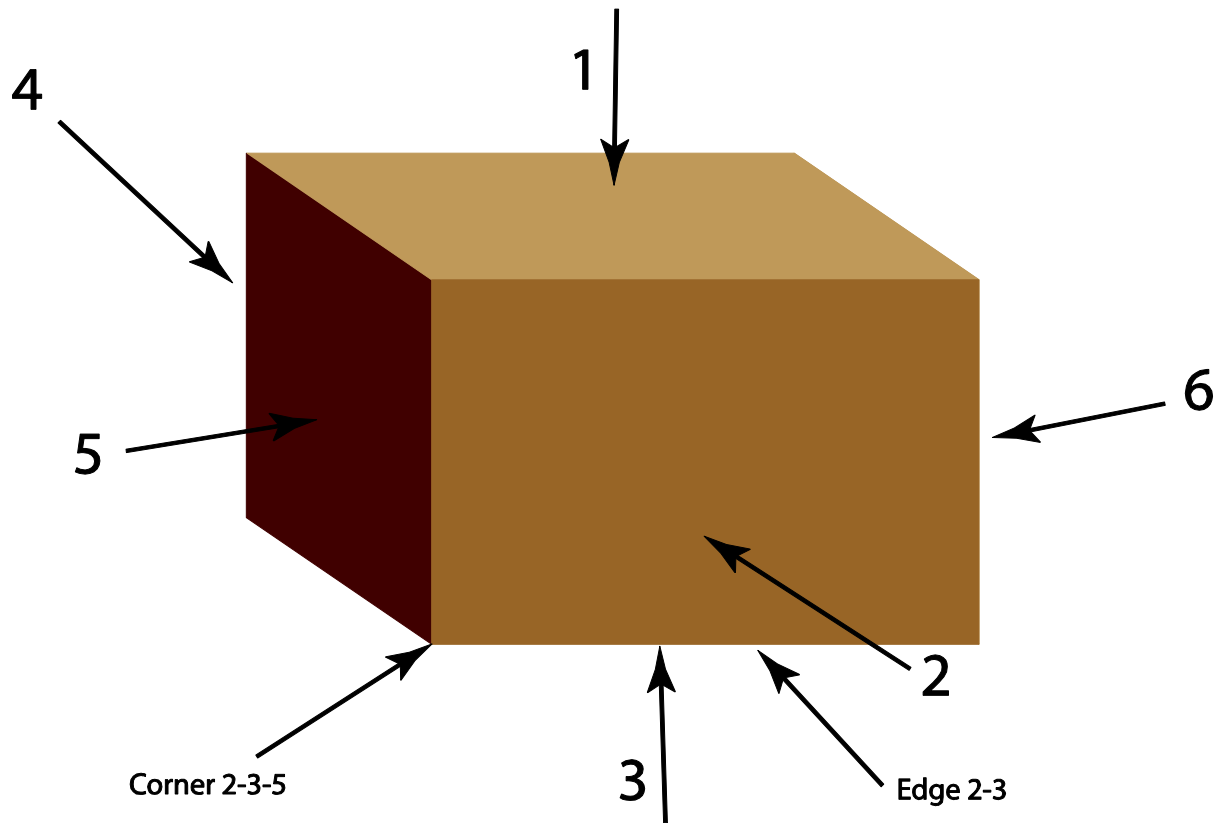

- Shock testing - Next, the package is dropped 9 times **not** in the large nylon tote bag.

Drop Number	Drop Height	Standard, flat, elongated, small (not in bag)	Two-Dimensional Envelopes and Mailers (not in bag)
1	18 (in)	Edge 3-4	Edge 4
2	18 (in)	Edge 3-6	Edge 6
3	18 (in)	Edge 4-6	Edge 5
4	18 (in)	Corner 3-4-6	Corner 4-6
5	18 (in)	Corner 2-3-5	Corner 2-5
6	18 (in)	Edge 2-3	Edge 2
7	18 (in)	Edge 1-2	Edge 5
8	<b>36 (in)</b>	Face 3	Face 3
9	18 (in)	Face 3	Face 1

- Vibration testing - After the drop testing the package is subject to a one hour fixed displacement vibration test.





## QVC QA Packaging & Labeling Guidelines – All Commodities

- Shock testing – Following the vibration testing the package is dropped an additional 7 times inside the large nylon tote bag.

Drop Number	Drop Height	Small (in a bag)
10	24 (in)	Face 4
11	24 (in)	Face 1
12	24 (in)	Face 2
13	24 (in)	Face 3
14	24 (in)	Face 1
15	24 (in)	Face 2
16	24 (in)	Face 4

### 5.5.4. Additional ISTA Test Procedures

1. Integrity Test Procedure 1A: Individual Packaged-Products 150 Lb (68Kg) or Less
2. Integrity Test Procedure 1B: Individual Packaged-Products Over 150 Lb (68Kg)
3. Integrity Test Procedure 1C: Extended Testing for Individual Packaged-Products 150 Lb (68Kg) or Less
4. Integrity Test Procedure 1C: Extended Testing for Individual Packaged-Products Over 150 Lb (68Kg)
5. Integrity Test Procedure 1E: Unitized Loads
6. Integrity Test Project 1F: Closed Reusable Transport Containers for Loads up to 150 Lb (68 Kg) or Less
7. Integrity Test Procedure 1G: Individual Packaged-Products 150 Lb (68Kg) or less
8. Integrity Test Procedure 1H: Individual Packaged-Products Over 150 Lb (68Kg)
9. Integrity-Plus Test Procedure 2A: Individual Packaged-Products 150 Lb (68Kg) or less
10. Integrity-Plus Test Procedure 2B: Individual Packaged-Products Over 150 Lb (68Kg)
11. General Simulation Performance Test Procedure 3A: Packaged-Products for Parcel Delivery Systems Shipment, 70 Kg (150 lbs) or Less
12. General Simulation Test Project 3C: Parcel Delivery System Shipments 150 Lb (68 Kg) or Less
13. General Simulation Test Project 3D: Small Packaged-Products 1 lb (454 g) or less Bagged for Shipment



14. General Simulation Test Project 3E: Unitized Loads of Same Product

## 5.6. Finished Goods Packaging Audits

During the PSFGA process and upon receipt of the bulk goods at the QVC distribution center a number of packaged-products are subjected to package testing. The finished goods package testing will consist of the same testing done during first piece QA (ISTA 1A or 3A). The number of packages tested will be determined by the size of the shipment and the applicable sampling protocol.

Sampling is normally performed in accordance with ANSI/ASQ Z 1.4, Special Inspection Level S-2, with an Acceptable Quality Level (AQL) of 6.5%.

The finished packaged-product will be compared to the packaging approved during the First-Piece QA Sample process. Any deviation from the approved packaging may be cause for rejection of the product or for imposition of vendor chargebacks.

The fact that a First-Piece QA Sample has passed package testing does not guarantee that goods from the PO receipt will also pass testing at the DC. Should the bulk goods fail finished goods package testing, the vendor is liable for any rework necessary to ensure the packaged-product passes transit testing.

## 5.7. Packaged-Product Damage

Any product damage incurred as a result of the package testing will be a cause for rejection of the product. This includes both structural failure and cosmetic damage which would make the product unacceptable to the customer. The product must be completely functional, without breakage, scratching, denting, scuffing or other damage to the product or its accessories.



### 5.7.1. Display Box Damage

Packages that enhance the value of the product, such as display boxes for collectible dolls, die cast cars and similar items, will not be accepted if the packages exhibit any indications of degradation.

### 5.7.2. Minor Degradation

Some minor degradation in the package itself (as distinguished from the contents of the package) is expected and acceptable. For example, depending on the product and packaging, QVC may accept, at its discretion, packages that incur minor corner or edge crushing, or minor scuffing to the carton graphics.

Some internal cushioning/packaging deformation and cracking is acceptable.

### 5.7.3. Unacceptable Package Degradation

QVC will not accept package-products which meet any one of the below conditions:

1. Exhibit complete cushion material fracture and/or cushion damage such that adequate product protection is compromised. Have holes in packages.
2. Have edge ruptures of the package to the extent it can no longer contain the product or support the product's weight.
3. Exhibit failure of packaging joints and surfaces which result in the internal packaging to lose its original configuration.

## 5.8. Beauty & Cosmetic Packaging Presentation

QVC understands the impact the overall package presentation can have on our customers. To improve the customer experience, QVC has developed a series of guidelines which will enhance the out-of-box presentation for beauty and cosmetic products. These guidelines focus on packaging classifications and requirements related to product price point, TSV's, giftable product, multi-component product, retail packaging, and packaging to prevent product void space.

### 5.8.1. Retail Price Point and Acceptable Packaging

To remain competitive and ensure we meet the customer expectation, QVC now requires a set of packaging classes based off the product retail price point. Section [Packaging Class and Acceptable Forms of Packaging](#) illustrates three



acceptable classes of internal packaging. Failure to meet the required packaging class will result in a First Piece QA failure.

---

**NOTE:** It is acceptable to package a product in a packaging class above what is required based on the retail price point.

---

### 5.8.2. Beauty TSV Packaging

A large part of QVC's success is based off the performance of our TSV's. TSV's give QVC and our vendors a great opportunity to generate new customers and retain existing ones. That being said, no matter what the product retail price point, all beauty TSV's must be packed in accordance to packaging Class A, see section [Packaging Class and Acceptable Forms of Packaging](#).

### 5.8.3. Giftable Product Packaging

We understand . a large portion of the business is driven by products meant to be gifted by our customer. It is extremely important to understand the impact a poorly packaged product can leave on our customer and the individual receiving the gift. That being said, no matter what the product retail price point, all giftable products must be packed in accordance to packaging Class A or B, see section [Packaging Class and Acceptable Forms of Packaging](#).

---

**NOTE:** Products which are meant to be advertised as gifts will be determined by the merchant and vendor during the initial PO negotiations.

---

### 5.8.4. Multi-Component Packaging

Some cosmetic kits have multiple components which make up the single item. It is important that multi-component kits be well packaged to ensure product stability throughout transit and a good presentation to the end customer. That being said, no matter what the product retail price point, all multi-component kits which contain three or more items and are packed in a vendor reshipper must be packaged in accordance with packaging Class A, see section [Packaging Class and Acceptable Forms of Packaging](#).

The only exception to the above rule is for smaller cosmetic kits which are packed in vendor jiffy bags. These kits must follow the vendor jiffy bag guidelines outlined in the section [Vendor Jiffy Bag Packaging Specifications](#). Examples of smaller cosmetic products which should be packed in a vendor jiffy bag include but are not limited to eye liners, blush, lip stick, etc.

### 5.8.5. Retail Packaging



Retail packaging does not only enhance the overall package presentation, but many times this packaging also holds important information related to the product and where it is produced. Thus, any product which has once been sold or would normally be sold with retail packaging at another retailer is also required to be used for QVC Purchase orders.

If used, and the retail packaging has been shrink wrapped and the carton has a face which is at least 3.5"x1.5", it is acceptable to apply the saleable unit barcode label to the shrink wrap vs. overpacking the retail packaging in an additional outer mailer to accommodate the barcode label.

### 5.8.6. Vendor Carton ID : Product OD Void Space

It is important to understand the negative impact of too much void space within a package. First, void space in many cases can lead to product damage because of product mobility. Second, void space can exhibit a poor customer presentation. Third, void space adds waste to the overall carbon footprint. Finally, in most cases, void space increases inbound and outbound shipping costs.

To limit excessive void space, a maximum of 35% void is allowable, however all void must be filled with approved internal cushioning/packing material.

**Void Space Formula** =  $100 * (1 - (\text{OD of product length} \times \text{OD of product width} \times \text{OD of product height}) / (\text{ID of package length} \times \text{ID of package width} \times \text{ID of package height}))$

To determine the product cube for a multi-component item, measure all components together as one or as they are positioned within the reshipper.

If retail packaging is used, the product cube can be determined based off the dimensions of the retail packaging vs. the actual product dimensions.

Please note, the max allowable void space is trumped by any vendor carton which meets the criteria in section [Automation Ready Vendor Reshippers](#) or by any package which needs to be designed to fit a saleable unit barcode label, limited quantity labeling or any other special label required to be on the reshipper package.

#### 5.8.6.1. Void Space Examples: Vendor Carton

##### Example 1: Unacceptable Vendor Carton Dimensions

The outside product dimensions (when packaged) are 20"x15"x10", which equal 3,000 cubic inches

The inside package dimensions are 25"x20"x15", which equals 7,500 cubic inches.

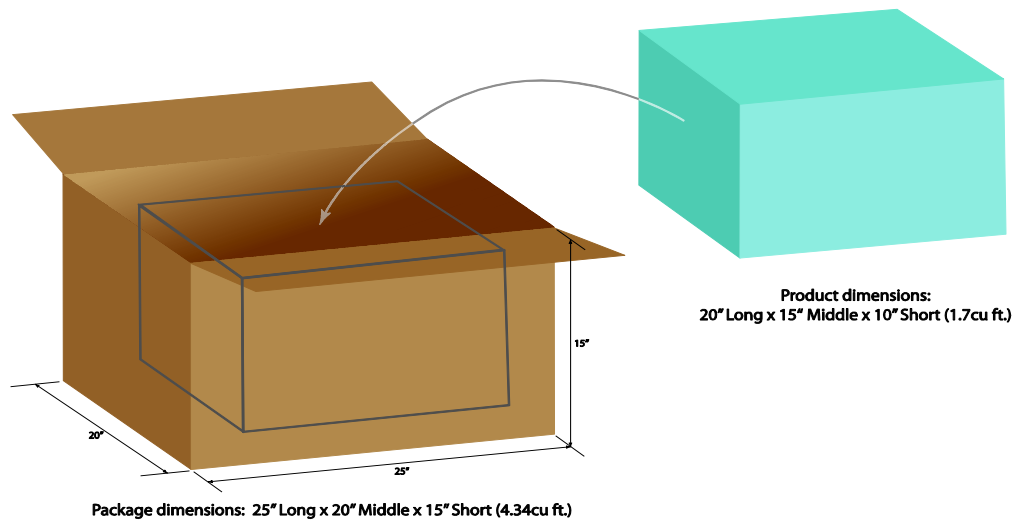

**Example 1: Unacceptable Vendor Carton Dimensions**

Using the Void Space Formula,  $100 * (1 - (3,000 / 7,500))$ , the internal void is 60%, which is greater than the allowable 35% and is thus not acceptable.

**Example 2: Acceptable Vendor Carton Dimensions**

The outside product dimensions (when packaged) are 10"x8"x6", which equals 480 cubic inches.

The inside package dimensions are 11"x9"x7.5", which equal 743 cubic inches.

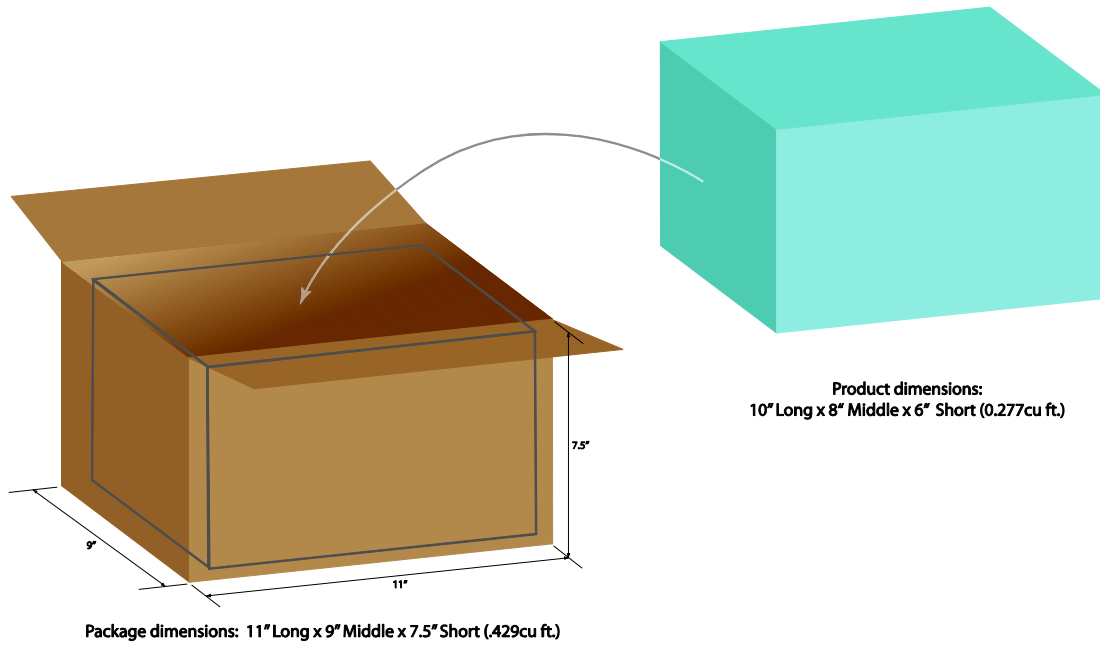

**Example 2: Acceptable Vendor Carton Dimensions**

Using the Void Space Formula,  $100 * (1 - (480/743))$ , the internal void fill is 35%, which is exactly the max allowable void space and is thus acceptable.



### 5.8.7. Packaging Class and Acceptable Forms of Packaging

The below chart illustrates the required packaging classes against the QVC retail price point for all beauty and cosmetic products. The QVC retail price point and packaging class for an item can be trumped if the product is a TSV, giftable, or multi-component.

<i>Packaging Class &amp; Acceptable Forms of Packaging</i>				
<i>Internal Packaging (Required)</i>		<i>Vendor Carton Box Style (Suggested)</i>		
<b>QVC Retail Price point</b>	<b>Class A</b>			
	<b>\$101 and above</b>	<i>Retail packaging</i>	<i>Regular slotted container (RSC)</i>	<i>Double cover container (DC)</i>
		<i>corrugated or plastic trays</i>	<i>Roll-end tray</i>	<i>Design style container with cover (DSC)</i>
		<i>Molded expanded polystyrene (ESP)</i>	<i>One piece folder (OPF)</i>	
		<i>Corrugated partitions</i>	<i>Five panel folder (FPF)</i>	<i>Snap or 1-2-3 bottom container with tuck top</i>
		<i>Corrugated partition tubes</i>	<i>Full telescope design style (FTD)</i>	
	<b>Class B</b>			
	<b>51 - \$100</b>	<i>Corrugate die-cut trays</i>	<i>Regular slotted container (RSC)</i>	<i>Center special full overlap slotted container (SFF)</i>
		<i>Molded paper pulp forms</i>	<i>Overlap slotted container (OSC)</i>	
		<i>Corrugated partitions</i>	<i>Full overlap slotted container (FOL)</i>	<i>Snap or 1-2-3 bottom container with RSC top</i>
		<i>Polyethylene Foam Sheeting</i>	<i>Center special slotted container (CSSC)</i>	
			<i>Center special overlap slotted container (CSO)</i>	
	<b>Class C</b>			
	<b>1 - \$50</b>	<i>Bubble wrap</i>	<i>Regular slotted container (RSC)</i>	<i>Center special full overlap slotted container (SFF)</i>
		<i>Kraft paper/ranpack</i>	<i>Overlap slotted container (OSC)</i>	
		<i>Packaging tissue paper</i>	<i>Full overlap slotted container (FOL)</i>	<i>Snap or 1-2-3 bottom container with RSC top</i>
		<i>Packaging Peanuts</i>	<i>Center special slotted container (CSSC)</i>	
		<i>Air Pillows</i>	<i>Center special overlap slotted container (CSO)</i>	

**NOTE:** As it relates to the Beauty Packaging Class table, the retail price point of a product is trumped by sections [Beauty TSV Packaging](#), [Giftable Product Packaging](#), and [Multi-Component Packaging](#). Also, as desired, the QVC Buyer and Packaging Engineer reserve the right to mandate or change vendor packaging to meet minimum expectations.





## 5.9. Why Packages Fail First-Piece Evaluation

The following list enumerates SOME of the most common reasons a product will fail the Packaging Evaluation portion of the First-Piece Sample Evaluation.

1. The product has a PO quantity over 5,000 units and is not packed in a reshipper.
2. Product leaks during testing or does not contain the required induction seal. (All products 8 fl oz and greater must contain a foil induction seal.)
3. Product breaks during package testing. (Products must be adequately packed to survive ISTA testing which is comprised of vibration testing and multiple drops.)
4. Product packaged in a retail box with an open face display window where the product is unprotected.
5. The package is not sealed. (All packages must be sealed.)
  - (1) The package is not sealed correctly. (Packages must be sealed parallel to the opening edge of the box.)
6. An otherwise automatable package is sealed with bands. (A package less than 36" x 24" x 24" may not use bands.)
7. The package punctures during testing. (The product is not sufficiently immobilized or protected and the product punctures the box from the inside.)
8. Products do not have a valid ISTA 3A test when it is needed for that category.
9. Poor quality packaging materials. (Poorly fused foams or low quality corrugated boxes.)
10. Products are submitted in a glossy reshipper.

## 5.10. Packaging Industry Contacts

International Safe Transit Association (ISTA)  
1400 Abbott Road, Suite 310  
East Lansing, MI 48823-1900  
Phone: (517) 333-3437 or (800) FOR-ISTA (800-367-4782)  
Fax: (517) 333-3813  
www.ista.org      E-mail: ista@ista.org



## QVC QA Packaging & Labeling Guidelines – All Commodities

UPS Professional Services (United Parcel Service)  
Package Lab  
1 UPS Way  
Hodgkins, IL 60525  
Phone: (708) 387-4560 or (877) 877-7229  
Fax: (708) 387-4555  
E-mail: Info@ups-psi.com

Federal Express Corporation  
Packaging Design and Development Department  
2856 Directors Cove  
Memphis, TN 38131  
Phone: (800) 633-7019  
Fax: (901) 922-6430  
www.fedex.com

Institute of Packaging Professionals (IOPP)  
481 Carlisle Drive  
Herndon, VA 22070  
Phone: (703) 318-8970 or (703) 814-4960  
www.packinfo.world.org E-mail: iopp@pkgmatters.com

Aero Rubber Company  
7501 West 99th Place  
Bridgeview, IL 60455  
Phone:(800) 662-1009

### **5.11. Literature and Documents**

Handbook of Corrugated and Solid Fibre Boxes, published by The Fibre Box Association, 2850 Golf Road, Rolling Meadows, IL 60008, Phone: (708) 364-9600.

Fundamentals of Packaging Technology, by Walter Soroka (Herndon, VA: Institute of Packaging Professionals), 1995. The “IOPP Bookstore” is an excellent source of publications on packaging.



## 6. Jewelry: Special Packaging Requirements

### 6.1. Internal & External Packaging

Appropriate internal and external packaging ensures a product arrives in good condition when shipped to the customer. The way a jewelry item is packaged at the factory impacts its appearance as it goes through transit. This in turn affects what the customers will see when they open their package.

#### 6.1.1. Polybags

Polybag packaging must meet the following criteria:

1. Each jewelry item requires its own individual polybag.
2. All polybags must be appropriate in size for the product they contain.
3. The polybag thickness must be consistent throughout the PO.
4. All polybags must be clear (transparent) polyethylene.
5. Polybags should be sealed using a self-locking tongue and groove closure (NO heat sealed, taped, or stapled polybags.)
6. Tied polybags are unacceptable.
7. All polybags must be labeled with the correct SKU and barcode label(s).
8. All polybags must meet QVC's polybag and film specification and labeling requirements, see section [Polybag and Film Requirements and Labeling](#).

##### 6.1.1.1. Polybag Size Requirements

1. Polybags must be of a minimum 3" x 2" size to enable proper placement of saleable unit barcode label.  
(1) Materials and dimensions of the polybag chosen for packaging must remain consistent throughout the life of the product.

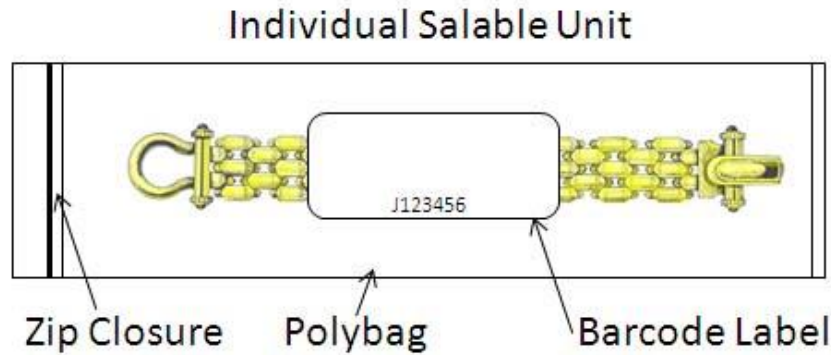

**Figure 6 - Typical Individual Saleable Unit**

### 6.1.2. Packaging

When packaging jewelry, the following requirements must be met:

1. Each individual selling unit must be packaged separately.
2. Sets (one saleable unit with multiply components) shipped in polybags must have one master polybag, and cannot be separate, stapled, taped, tied or sewn together.
3. QVC does not allow paperboard cartons to be sealed (taped, stapled, etc.) shut.
  - (1) Paperboard cartons used to package sets should utilize the reverse-tuck-top with locking flap design.
    - (a) A reverse-tuck-top with locking flap design does not require tape, staples, ties to seal the carton.
4. All items must have some type of outer packaging. No item may be shipped without a protective covering which must contain the sku sticker and bar code label.

### 6.2. Exclusions

When packaging jewelry, the following materials are unacceptable to use:

1. Rubber bands are unacceptable
2. Tissue paper is unacceptable
3. Straight pins are unacceptable
4. Plastic clips are unacceptable
5. Staples are unacceptable
6. Sticky tape is unacceptable



### 6.3. Tarnish Prevention/Sulfur-Free, Chlorine-Free

Sulfur and chlorine will tarnish jewelry. The following must be met for tarnish prevention:

1. Anti-tarnish strips cut to an appropriate size are required.
2. Packaging must not contain any sulfur and/or chlorine.

Packaging must not contain any sulfur and/or chlorine, or any other chemical which contributes to accelerated tarnishing of silver product (e.g., boxes which contain free sulfur or chlorine.)

### 6.4. Presentation Cases

QVC ships all product/jewelry items to customers in a presentation case. Presentation cases are supplied by either the vendor or QVC.

---

**NOTE:** All watches must have a vendor supplied presentation case.

---

#### 6.4.1. QVC-Provided Presentation Case

If the PO states a QVC Presentation case will be used, the vendor does not need to submit a presentation case. During First-Piece Evaluation, QVC QA will determine the appropriate QVC presentation case and establish a “pack recipe” for QVC’s internal use.

#### 6.4.2. Vendor Presentation Case

If the PO states the vendor will supply the presentation case, the vendor must submit two (2) presentation cases as a component of the First-Piece samples during the First-Piece Process. During the First-Piece Evaluation, QVC QA will determine if the packaging is acceptable.

All presentation cases must meet the following criteria:

1. Presentation cases must withstand shipping.
  - (1) During 1<sup>st</sup> piece QA QVC may conduct ISTA transit testing to ensure the product is packaged sufficiently for small parcel transit.
2. Presentation cases must secure and immobilize the product.
3. Presentation cases must provide a pleasing and appropriate display for the product.
4. Presentation cases must be sulfur-free and chlorine-free.



Vendor Packaged items (VCO) and or Vendor Presentation Cases must be properly barcoded, directly on the Packaging/Presentation Case. If the base of the Presentation Case is too small to properly position the barcode label, the label must be placed on a self-sealing polybag enclosing the packaged item.

### 6.5. Specific Product-Type Packaging

Each of the following product types must follow the specific packaging requirements.

All jewelry not packaged in a vendor presentation case must be packaged in an individual polybag.

#### 6.5.1. No Metal on Metal

To protect against scratching and scuffing, none of the individual jewelry pieces in a set should be able to touch metal on metal. It is permissible to pack all but one of the pieces in individual polybags of the same size, material, and thickness. The final piece should be inside the larger outer polybag that contains all of the pieces. The polybag(s) must be sealed using a self-locking tongue and groove closure.

#### 6.5.2. Sets

A “set” is a group of two or more pieces of jewelry sold to the customer as one saleable unit. A set may include a combination of jewelry types or multiples of the same type of jewelry.

Each item in a set is required to be packaged individually and then placed together in one polybag.

(Bag-in-a-Bag) Please see the following: [“Figure 7 - Illustrated Packaging Guidelines – Earrings”](#)

#### 6.5.3. Rings

Rings are required to be packaged in individual polybags.

#### 6.5.4. Necklaces, Bracelets, Anklets, Pins, Pendants Without Chains



Necklaces, bracelets, anklets, pins, and pendants without chains should be packaged in individual polybags.

### 6.5.5. Pendants With Chains

Pendants must be attached to the chain. A polybag may be used on the pendant, with the complete item placed in a larger polybag which houses both the pendant and chain. Bundling is not acceptable.

### 6.5.6. Earrings

To prevent damage and scuffing, pairs of earrings should be packaged as a “bag in a bag”. One earring is placed in an individual polybag. The polybag is then placed in another polybag which houses both the first bag and the second earring. See the following figure.

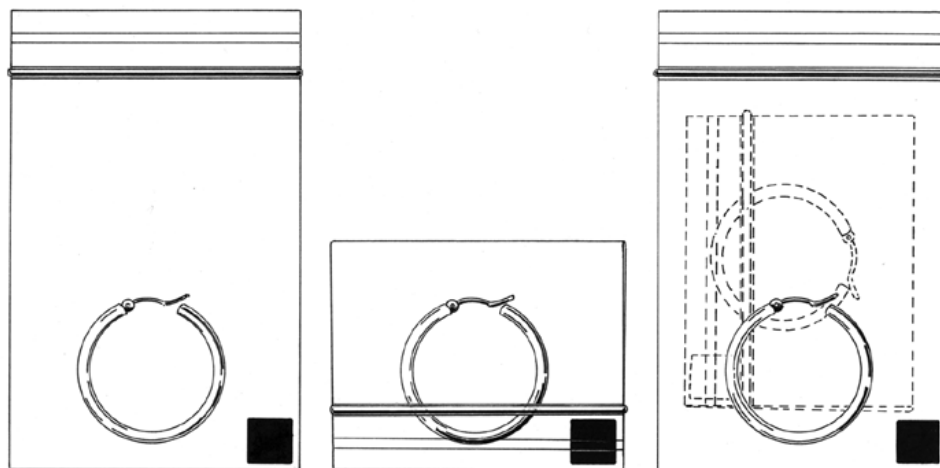

Figure 7 - Illustrated Packaging Guidelines – Earrings

### 6.5.7. Watches

All watches must have a vendor supplied presentation case. All warranties and other literature must be enclosed in the presentation case when submitting your product for First-Piece QA sample evaluation just as they would be in the shipment.



## 7. Packaging for Shipment to a QVC Distribution Center

### 7.1. Overview

This section addresses the requirements for packaging and labeling of all product categories which are shipped into a QVC Distribution Center (DC). By adhering to the requirements outlined in this section, a QVC DC is able to receive and process product quickly and with less handling in order to fulfill a QVC customer order within 48 hours of receipt.

### 7.2. Packaging

It is the vendor's responsibility to ensure all product arrives to the QVC DC without damage. QVC gives the vendor a great deal of latitude in deciding how best to ship product in an effort to reduce potential sources of freight damage while being able to maximize transportation efficiencies.

#### 7.2.1. Definitions of QVC Packaging Components

**Saleable Unit:**

A saleable unit refers to one (1) QVC SKU (e.g. H12345 000000) as it will be shipped to a QVC customer.

**Primary Packaging:**

First level of packaging which comes in direct contact with the product. Examples of a primary package include polybags, plastic clamshell, retail box, etc.

**Vendor Reshipper:**

A sturdy outer package which contains one (1) saleable unit which would ship directly to a QVC customer with minimum processing and handling. A reshipper may be the primary product packaging or an over-box.

---

**NOTE:** During 1<sup>st</sup> piece QA, QVC will package test vendor reshipper packaging to verify the packaged-product is suitable for small parcel transit.

---

**Inner Carton:**

An inner carton (or inner pack) could be a carton or polybag and always must contain more than one (1) saleable unit. The inner carton(s)/polybag(s) are then packed inside a master carton.

**Master Carton:**

A master carton is a corrugate container which consolidates saleable units for the shipment to the QVC DC.





**Pallet:**

A pallet is a wooden base frame used for transporting and storing product. QVC does not accept plastic pallets.

### **7.3. Accessories, Apparel, Hardgoods, Cosmetics & Home Textiles Special Inbound Packaging Requirements**

#### **7.3.1. Primary packaging**

A primary package is required. An acceptable form of primary packaging will be determined during 1<sup>st</sup> piece QA.

#### **7.3.2. Vendor reshipper**

The use of a vendor reshipper is determined during 1<sup>st</sup> piece QA. See section [Vendor Reshipper](#) for more details.

#### **7.3.3. Inner carton**

Inner carton packaging is optional, if used, the following criteria must be met.

1. Must contain more than one (1) saleable unit.
2. Do NOT mix SKUs within an inner carton/polybag.
3. The number of units packed must be consistent among all inner cartons/polybags, with the exception of a partial.
4. Use of a partial inner carton/polybag is acceptable, but it may NEVER contain mixed SKUs.
5. Do NOT pack bundles of a single SKU in an inner carton/polybag.
6. Do NOT shrink wrap, band or strap an individual inner carton.
7. Do NOT use packing peanuts, waded/shredded newspaper or paper to fill any void space within an inner carton.

#### **7.3.4. Master Carton**

Master carton packaging is only required if the product doesn't ship to QVC in a vendor reshipper.

---

**NOTE:** If using master cartons all saleable units must be packaged within a master carton.

---

If master carton packaging is used the following criteria must be met.



## QVC QA Packaging & Labeling Guidelines – All Commodities

1. The master carton must contain a minimum of 4 saleable units, with the exception of one partial.
2. The master carton must NEVER have mixed QVC SKU's within the package.
3. The number of saleable units packed must be consistent among all masters for each QVC SKU, with the exception of one partial.
4. Use of one partial master carton is acceptable, but it may NEVER contain mixed SKUs.
5. Do NOT shrink wrap, band or strap an individual master carton and do not shrink wrap, band or strap multiple master cartons together.
6. As needed, to immobilize saleable units within the master carton it is acceptable to use approved packaging void fill materials, see section [Internal Cushioning and Immobilization Materials](#). Please note it is not acceptable to use empty retail or saleable unit packaging as void fill.
7. If product is shipping from a domestic US factory, QVC recommends that high quality 3-ply, single wall corrugate material be used.
8. If product is shipping from a foreign factory, QVC recommends that 5-ply, double wall corrugate material be used.
9. QVC recommends the H-pattern tape method for master carton packaging.

### 7.3.4.1 Max Master Carton Dimensions & Weight

MASTER CARTON MAX DIMENSIONS & WEIGHT				
PRODUCT CATEGORY	LENGTH	WIDTH	HEIGHT	WEIGHT
Accessories, Hardgoods, Home Textiles	40" (101.60cm)	24" (60.96cm)	24" (60.96cm)	40 lbs. (18kg)
Apparel	24" (60.96cm)	18" (45.72cm)	12" (30.48cm)	40 lbs. (18kg)

---

**NOTE:** There is no minimum master carton size or weight for Accessories, Apparel, Hardgoods, Cosmetics and Home Textiles product lines.

---

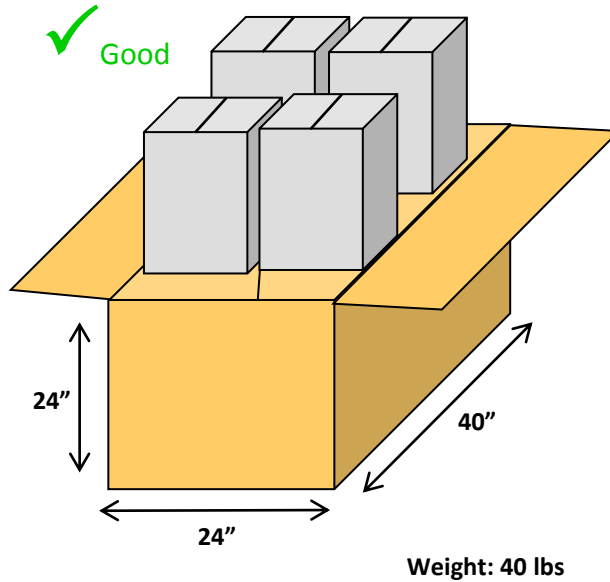

**Figure 8 - Typical Accessories, Hardgoods, Cosmetics & Home Textiles Master Carton**

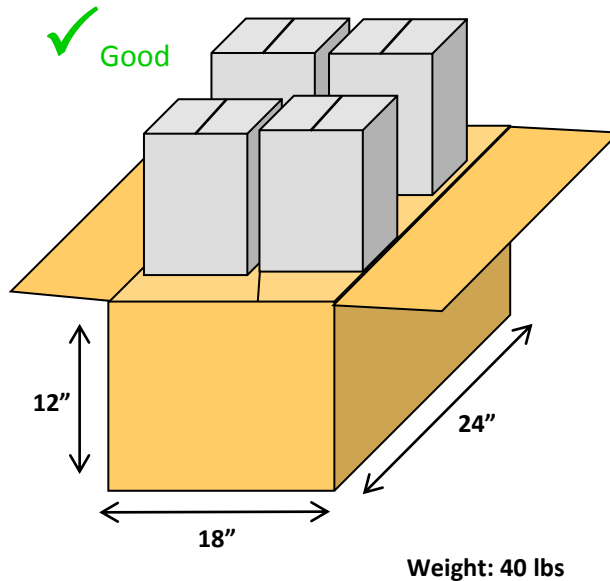

**Figure 9 - Typical Apparel Master Carton**

### 7.3.5. Gaylord Packaging

As a general rule of thumb gaylord packaging should not be used to ship product to the QVC DC because of the inefficiencies to offload and repack the product. In addition, gaylord packaging can present storage issues due to space limitations at the QVC DC's. Dealt with on a case by case basis a vendor may request to use gaylord packaging. These requests must be sent



to the QA Packaging Engineer where a review will be done with the DC Area Inbound Manager & Inventory Control Manager for approval.

### 7.3.6. Pallet

Pallets are Optional. If used, the following criteria must be met.

1. Use 48 inch x 40 inch stringer pallet that follows Grocery Manufacturers Association (GMA) standards.
2. Pallets must be constructed of dense hardwood material only. Wood must be knot and defect free. Plastic pallets are not accepted.
3. There must be no protruding nail heads and all bent over nails must be driven below the surface of the deck boards.
4. Whenever possible, cartons must be placed on the pallet so that labels face outward
5. The load on the pallet should be square with no lean.
6. No overhang of product is accepted.
7. Do not band or strap material to the pallet.
8. Shrink wrap is acceptable for securing master cartons to a pallet load.
9. While there is no height restriction requirement for palletized product, the load of product placed on a pallet should not be so heavy as to cause the bottom layer of cartons to be crushed.

#### 7.3.6.1 Mixing SKUs on a Pallet

Whenever possible, vendors should avoid mixing SKUs from the same purchase order on a single pallet. However, if the quantity ordered of a single SKU from a purchase order is not sufficient enough to fill a 48 inch x 40 inch standard pallet, SKUs may be mixed as long as they are from the same purchase order.

---

**NOTE:** NEVER mix SKUs from different QVC purchase orders on a single pallet.

---

## 7.4. Jewelry; Special Inbound Packaging Requirements

### 7.4.1. Primary Package

A primary package is required and must be either a clear (transparent) zip-lock polybag or vendor presentation case (VCO).

To accommodate the saleable unit barcode label the individual polybag must be at least 3" x 2".

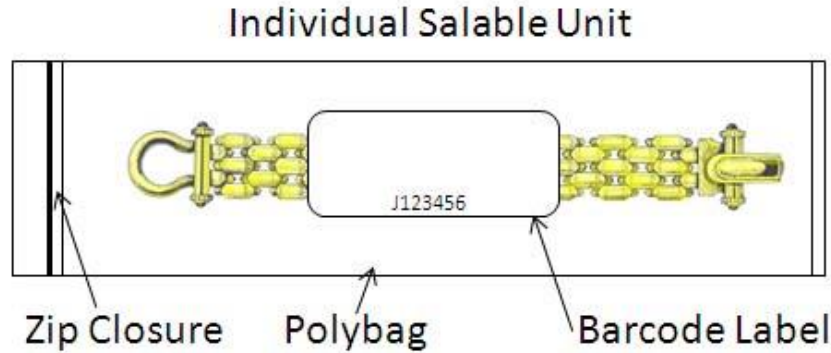

**Figure 10 - Typical Jewelry Saleable Unit**

### 7.4.2. Inner Pack Requirements

All saleable units packed in a polybag are required to be packed into an inner pack. Vendor supplied presentation cases are not required to be packed into inner packs. An inner pack can be a larger polybag or a corrugate carton.

The following requirements must be met for each inner pack:

1. Must contain either 10, 25 or 50 saleable units. (Do not pack more than 50 units in one inner pack and do not pack less than 10 units, unless it is the partial inner pack).
2. Must contain the same number of saleable units, with the exception of the partial.
3. Do NOT mix SKUs within an inner pack, including the partial inner pack.
4. Do NOT pack bundles of a single SKU in an inner pack, bundling of SKUs is not accepted.

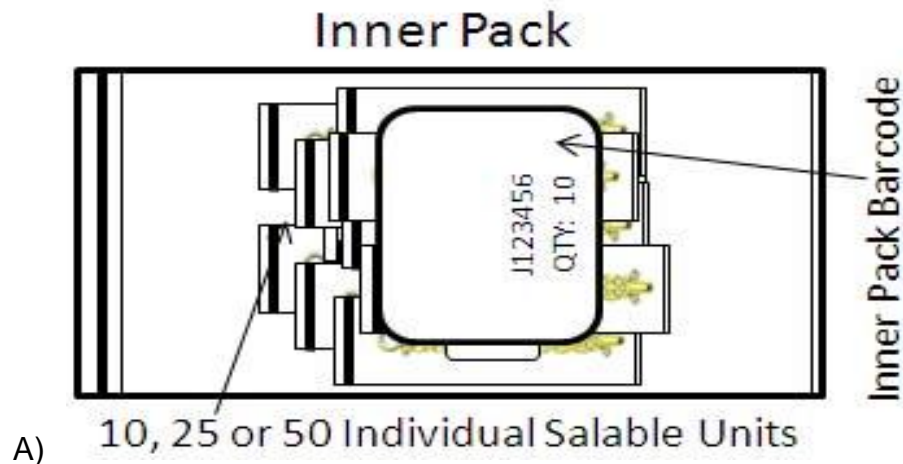

**Figure 11 - Typical Jewelry Inner Pack**



### 7.4.3. Master Cartons

QVC requires all jewelry product to be shipped within master carton packaging. QVC does not accept master cartons made of any other material other than corrugate. However, QVC will accept master cartons packed into wood crates or metal tins which may be a requirement for air freight shipments.

The following requirements must be followed for each master carton:

1. The master carton must contain a minimum of 4 saleable units, with the exception of one partial.
2. Each master carton must contain the same number of saleable units/inner packs, with the exception of one partial master carton.
3. Do NOT shrink wrap, band or strap an individual master carton and do not shrink wrap, band or strap multiple master cartons together.
4. As needed, to immobilize saleable units within the master carton it is acceptable to use approved packaging void fill materials, see section [Internal Cushioning and Immobilization Materials](#). Please note it is not acceptable to use empty retail or saleable unit packaging as void fill.
5. If product is shipping from a domestic US factory, QVC recommends high quality 3-ply, single wall corrugate material be used.
6. If product is shipping from a foreign factory, QVC recommends 5-ply, double wall corrugate material be used.
7. QVC recommends the H-pattern tape method for master carton packaging.

#### 7.4.3.1. Minimum & Maximum Master Carton Dimensions & Weight

MASTER CARTON MIN & MAX DIMENSIONS & WEIGHT							
PRODUCT CATEGORY	MINIMUM DIMENSION			MAX DIMENSION			MAX WEIGHT
	LENGTH	WIDTH	HEIGHT	LENGTH	WIDTH	HEIGHT	
Jewelry	10" (25.4cm)	8" (20.32cm)	6" (15.24cm)	24" (60.96cm)	17" (43.18cm)	13" (33.02cm)	40lbs (18kg)

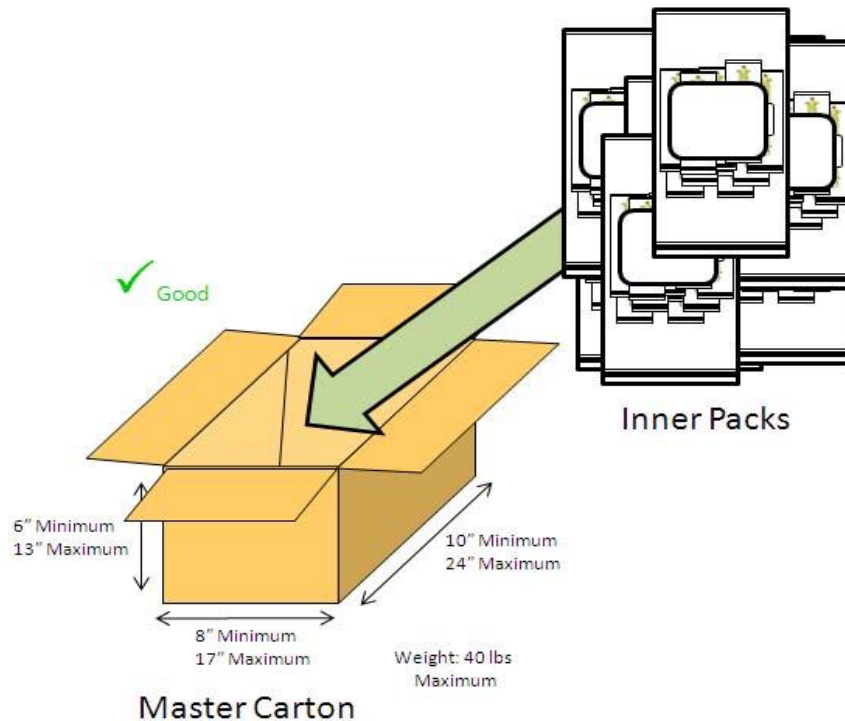

**Figure 12 - Typical Jewelry Master Carton**

### **7.4.3.2. Packing Multiple Small Master Cartons into an Over Box**

In situations where a vendor has multiple small size master cartons which they do not want to ship loosely for fear of damage or loss it is acceptable to pack the master cartons into an over box. An over box is never considered a master carton. Upon receipt all master cartons contained within the over box will be removed and put away individually.

When using an over box, the following criteria must be met.

1. Each master carton packed into the over box must comply with all master carton packaging and labeling requirements as outlined in this chapter.
2. Do NOT mix master cartons from multiple purchase orders into an over box.
3. There are no specific restrictions on the carton dimensions of an over box so it may exceed the current maximum carton dimensions for a master carton if needed.
4. There are no specific restrictions on the total weight of an over box as long as it is in compliance with your freight carrier's carton weight limits.
5. A bar code is NOT required, but the following information must be included on the over box label:
  - (1) Ship To Addresses of the QVC distribution center as indicated on the QVC purchase order.



## QVC QA Packaging & Labeling Guidelines – All Commodities

- (2) QVC 6-Digit Purchase Order Number.
- (3) Count of master cartons in the over box (QTY: ## Cartons).
6. The over box must be boldly and legibly marked “CONTAINS MULTIPLE MASTER CARTONS” on the four sides of the carton.
7. Place label on one of the longer sides of the over box. Only one label is required per carton.

### **7.4.3.3. Mixing SKUs in a Master Carton**

As a rule, vendors should not mix SKUs in a master carton. However, when purchase order quantities are too small (e.g. back orders, waitlist orders) to be able to pack by individual SKU without going below the minimum master carton dimensions it is acceptable to mix SKUs in a master carton.

If mixing SKUs into one master carton, the following requirements must be met.

1. All mixed SKUs combined into a master carton must be from the same QVC purchase order (DO NOT mix SKUs in one carton from multiple purchase orders).
2. When possible, continue to pack saleable units into standardized inner pack quantities. DO NOT loosely place a mix of saleable units among different SKUs within the master carton.
3. The master carton must be boldly and legibly marked “CONTAINS MIXED SKU’s” on the four different sides of the carton.
4. The bar code used on the master carton label should reflect the SKU with the greatest quantity of units contained within the carton.
5. The quantity of saleable units on the master carton bar code label must reflect the total quantity of units for all SKUs contained within the master carton.

### **7.4.4. Standardized Pack Quantities**

Inner pack and master carton quantities must be standardized by the individual saleable unit (or SKU) for all shipments into a QVC DC. For example, if a single SKU is packed into inner packs containing 10 units each and then 15 inner packs are placed into a master carton for a total of 150 units per master, all subsequent shipments must be packed in the exact same method. The only exception is for the partial inner pack or master carton when necessary.





### 7.4.5. Pallet

Pallets are optional. If used, the following criteria must be met:

1. Use a 48 inch x 40 inch stringer pallet which follows Grocery Manufacturers Association (GMA) standards.
2. Pallet must be constructed of dense hardwood material only. Wood must be knot and defect free. Plastic pallets are not accepted.
3. There must be no protruding nail heads and all bent over nails must be driven below the surface of the deck boards.
4. Cartons must be placed on the pallet so the labels face outward.
5. The load on the pallet should be square with no lean.
6. No overhang of product is accepted.
7. Do not band or strap material to the pallet.
8. Shrink wrap is acceptable for securing master cartons to a pallet load.
9. While there is no height restriction requirement for palletized product, the load of product placed on a pallet should not be so heavy as to cause the bottom layer of cartons to be crushed.
10. It is acceptable to mix-SKUs from the same QVC purchase order on a single pallet. The pallet label must include the phrase “CONTAINS MIXED SKUS” in bold and legible print.



## 8. Package Barcode Labeling Requirements

QVC's distribution centers process a high volume of product which is delivered in various configurations every day. Therefore, the use of proper labeling is critical to ensure the expeditious receipt of product into available inventory and successful processing of the product through the distribution center. Prior to shipping into the QVC DC, all accessories, apparel, hardgoods, and home textile products require an acceptable barcode label on each saleable unit and master carton. Jewelry requires an acceptable barcode label on each saleable unit, inner carton, and master carton. Bar codes are not required on pallet labels.

---

**NOTE:** Most of the labeling requirements mentioned in section eight are specific to accessories, apparel, hardgoods, cosmetics and home textile product lines. Section ten of this document lists the special labeling requirements specific to Jewelry only.

---

### 8.1. The Saleable Unit Barcode Label

A saleable unit bar code label must be placed on the outermost packaging of the saleable unit. The label must always be applied smoothly so there are no bumps or wrinkles which could interfere with successful scanning of the bar code. QVC will only accept printer generated labels. Handwritten labels are not acceptable.

#### 8.1.1. Saleable Unit Label Requirements

An individual saleable unit label **MUST** have the following information:

1. A bar code in a QVC accepted bar code format.
2. The complete QVC SKU in a human readable format using a minimum lettering height of  $\frac{1}{8}$  inch (0.32 cm).

Although not required, it is acceptable to also show the following information on a saleable unit label:

1. Color or size information (e.g. Red, Size Small or Medium).
2. Country of Origin.

---

**NOTE:** Inclusion of the country of origin (COO) on the saleable unit bar code label does not satisfy U.S. Customs & Border Protection's marking requirements. Under the customs marking laws, with few exceptions, every article of foreign origin imported into the US shall be marked in a conspicuous place as legibly, indelibly and permanently as the nature of the article will permit, in such manner as to indicate to an ultimate purchaser in the U.S. the English name of the country of origin of the article, at the time of importation into the Customs territory of the U.S.

To avoid marking issues with customs, the vendor should mark goods with the country of origin at time of manufacture, following the requirements as set forth in 19CFR134.

---



## QVC QA Packaging & Labeling Guidelines – All Commodities

**DO NOT** show any reference to multiple quantities on a QVC saleable unit label or on a saleable unit’s packaging as the following examples indicate. With the rapid handling of product through our distribution centers, seeing this type of information can confuse QVC associates to think the package contains more than one saleable unit.

- “Set of 3...”
- “4 Piece Set...”
- “10 Set...”

If the information exists it will need to be covered over prior to delivery with a label or opaque tape. It is not acceptable to cross out the information with a marker or pen.

The following images represent compliant saleable unit labels:



**Figure 13 - Compliant Saleable Unit Labels**

The following images represent non-compliant saleable unit labels:

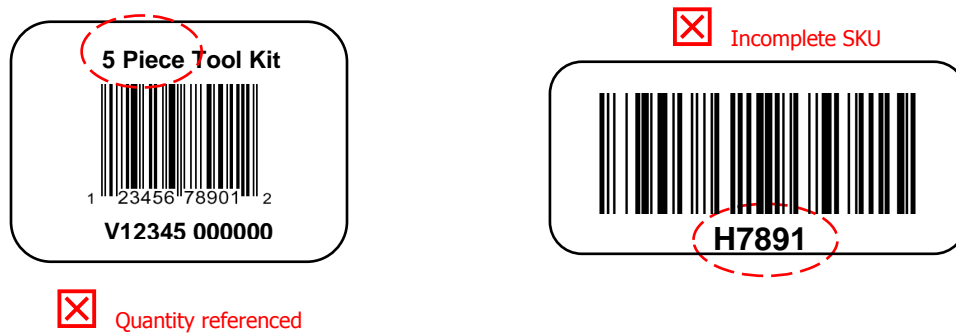

**Figure 14 - Non-Compliant Saleable Unit Labels**

### 8.1.2. Saleable Unit Label Placement

As a general rule, the saleable unit bar code label must be placed on the largest, flattest surface dimensionally of the outermost package of the saleable unit. However, there are other packaging configurations where this rule is neither feasible nor preferred by QVC due to special handling requirements within the distribution centers. Please review the list below and follow the label placement requirements for your specific package configuration.



### 8.1.2.1. Label placement for corrugate vendor reshipper:

When applying a saleable unit barcode label to a corrugate vendor reshipper, the following criteria must be met:

1. Place label on the largest, flattest surface of the carton (**NOTE:** QVC does not specify exactly where on the largest, flattest surface leaving it to the vendor's discretion.)
2. Label placement must be consistent from unit to unit.
3. Only one bar code label is required per saleable unit.
4. **DO NOT** place a label across a carton seam **OR** around a carton edge.
5. **DO NOT** place the label underneath a blister pack, clam shell, or shrink wrap.
6. **DO NOT** place clear tape over the bar code label as this could interfere with successful scanning of the bar code label.

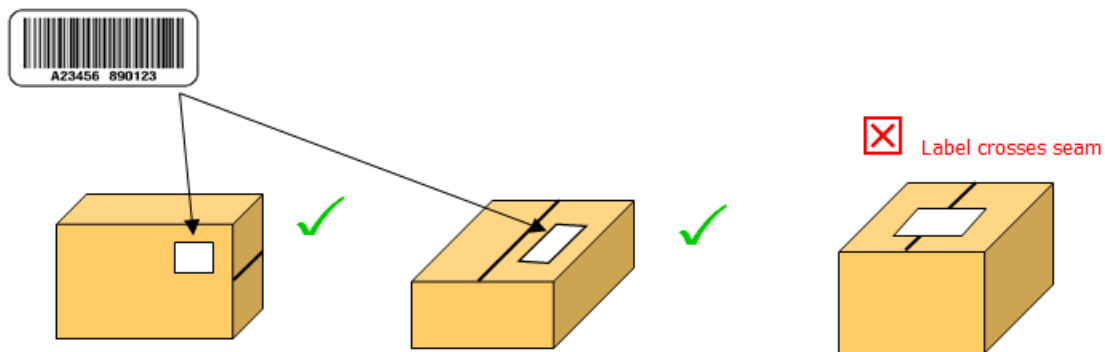
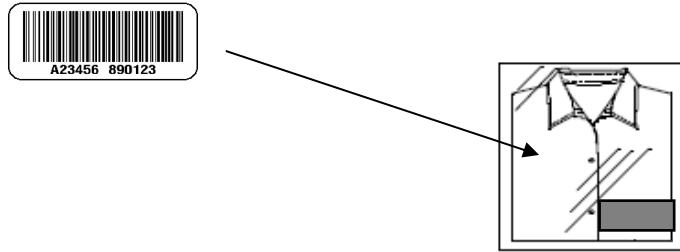

Figure 15 - Compliant and Non-Compliant Label Placement

### 8.1.2.2. Label placement for Apparel product in a polybag:

When applying a saleable unit barcode label to a polybag, the following criteria must be met:

1. When facing the polybag, place label in the lower right portion of the polybag keeping it away from the edges.
2. **DO NOT** use the label to seal a polybag closed.
3. **DO NOT** place a bar code label underneath the polybag.



**Figure 16 - Label Placement – Apparel Polybagged Item**

### 8.1.2.3. Label placement for garments on hanger:

Place the label on the polybag at the front left shoulder of the garment. Keep the label away from the edges of the polybag.

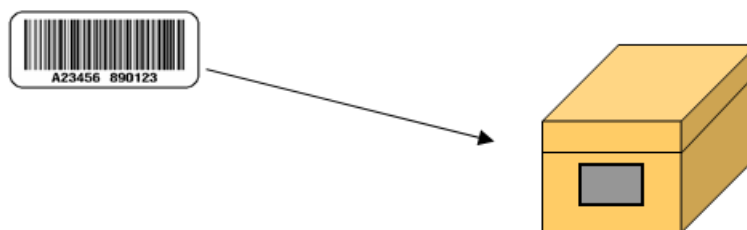

**Figure 17 - Label Placement - Garment on Hanger**

### 8.1.2.4. Label placement for shoes and boots:

When applying a saleable unit barcode label to a vendor shoe box, the following criteria must be met:

1. Place label on one of the smaller ends of the shoebox. If a vendor's own bar code label already exists at one end of the shoebox place the QVC bar code label on the opposite end.
2. Each shoebox must be secured with a plastic band (a rubber band is not acceptable).



**Figure 18 - Label Placement - Shoes and Boots**



### 8.1.2.5. Label placement for rolled carpet:

When applying a saleable unit barcode label to a rug, the following criteria must be met:

1. Place a label at each short end of the rolled carpet
2. It is acceptable to place clear tape over the label for added security

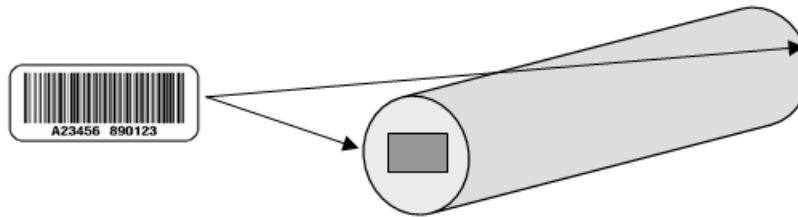

Figure 19 - Label Placement - Rolled Carpets

### 8.1.2.6. Label placement for undersized products:

If a product's outer packaging is too small to place a compliant (properly sized) saleable unit bar code label, then the product must be over-packed to accommodate the label size. Below are the standard barcode sizes for each product category:

Standard Label Size			
Category	Saleable Unit	Inner Carton	Master Carton
Accessories	3.5"x1.5"	3.5"x1.5"	6"x4"
Apparel	3.5"x1.5"	3.5"x1.5"	6"x4"
Hardgoods	3.5"x1.5"	3.5"x1.5"	6"x4"
Home Textiles	3.5"x1.5"	3.5"x1.5"	6"x4"
Jewelry	2.25"x1"	4"x2"	4"x3"

Alternative saleable unit barcode sizes		
2.25"x1"	2.75"x1"	4"x2"

---

**NOTE:** Please consult with your QVC Supplier Relationships Manager before using an alternative saleable unit barcode label size.

---



## 8.2. The Inner Carton Label

An inner carton label must be placed on the side of the carton or polybag so that it will be facing up when the master carton is open. Although a bar code is not required on the inner carton label, QVC will only accept printer generated labels. Handwritten labels are not acceptable.

---

**NOTE:** A barcode label is not required for accessories, apparel, hardgoods, cosmetics or home textile inner carton packaging. Although a bar code is not required on an inner carton label, QVC will only accept printer generated labels. Handwritten labels are not acceptable.

---

An inner carton label **MUST** have the following information:

1. The complete QVC SKU in a human readable format using a minimum lettering height of ¼ inch ( .635 cm).
2. The total quantity of saleable units contained within the inner carton. The quantity must be displayed as a number only, do not use the words “Units”, “Pieces”, “PCS” etc.
3. If a partial inner carton/pack is required, the word ‘PARTIAL’ must be boldly and legibly marked on the label and the quantity of units is adjusted accordingly.

The following image represents a compliant inner carton label:

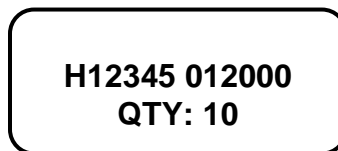

**Figure 20 - Compliant accessory, apparel, hardgoods, & home textile Inner Carton Label**

### 8.2.1. Inner Carton Label Placement

Inner carton labels must be placed on the carton “face up” in such a way the label is immediately visible as soon as the master carton is opened.

The following image demonstrates four (4) inner cartons being placed in a master carton with the inner carton labels placed facing up:

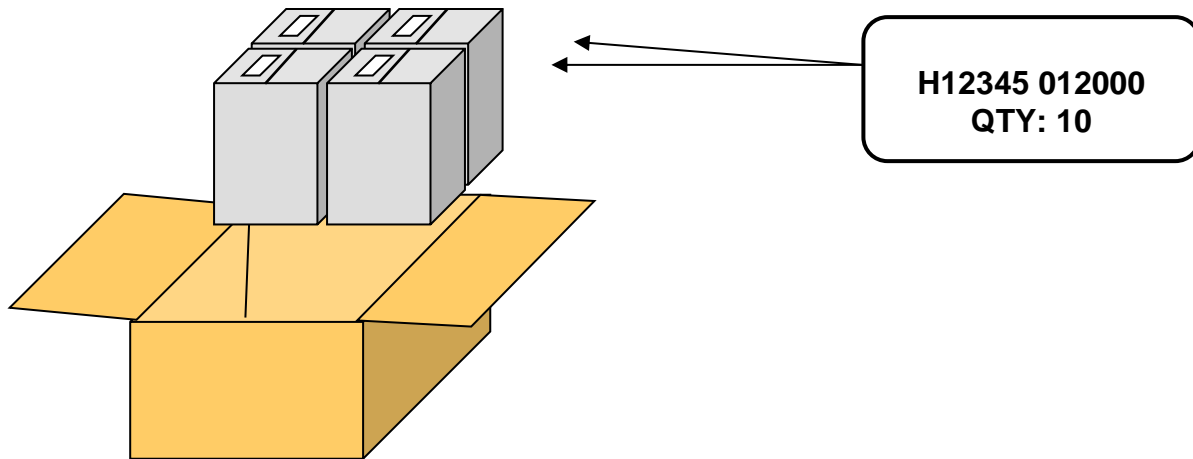

Figure 21 - Compliant Inner Carton Labeling

### 8.2.2. Inner Polybag Placement

When placed on a polybag, the inner pack bar code label should be placed in the center of the bag.

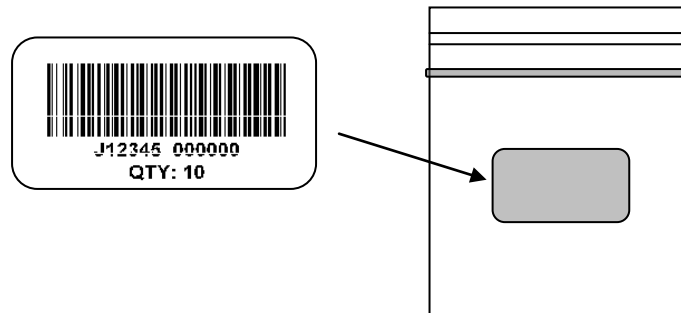

Figure 22 - Example of a Compliant Inner Pack Label Placement – Polybag

## 8.3. The Master Carton Barcode Label

A master carton bar code label must be placed on the smallest, flattest surface dimensionally of the master carton, except if this is the top (open end of carton) or bottom of the carton in which case the label must then be applied to the middle size side panel. The label must always be applied smoothly so there are no bumps or wrinkles which could interfere with a successful scanning of the bar code. QVC will only accept printer generated labels. Handwritten labels are never permitted.

### 8.3.1. Master Carton Label Requirements

A master carton label MUST have the following information:

1. A bar code in a QVC accepted bar code format.





## QVC QA Packaging & Labeling Guidelines – All Commodities

2. The complete QVC SKU in a human readable format using a minimum lettering height of ¼ inch ( .635 cm).
3. The total quantity of individual saleable units contained within the master carton. The quantity must be displayed as a number using a minimum lettering height of ¼ inch (0.635 cm), do not use the words “Units”, “Pieces”, “PCS” etc.
4. The QVC 6-digit Purchase Order Number using a minimum lettering height of ¼ inch (0.635 cm).
5. If a partial master carton is required, the word ‘PARTIAL’ must be boldly and legibly marked on the label and the quantity of units is adjusted accordingly.
6. The “Ship To” address of the QVC distribution center as indicated on the QVC purchase order using a minimum lettering height of ¼ inch (0.635 cm).
7. Vendor “Ship From” address using a minimum lettering height of ¼ inch (0.635 cm).

The following information is acceptable to show on a master carton label but is NOT required:

1. Carton count (e.g. Carton # of ##).
2. When carton count is included on the QVC master carton label, the carton numbers must be printer generated and cannot be handwritten.

---

**NOTE:** Both QVC approved label suppliers will NOT include carton count on the QVC master carton labels.

---

DO NOT show any reference to multiple quantities on a QVC master carton label OR on the master carton itself as the following examples indicate:

- “Set of 3...”
- “4 Piece Set...”
- “10 Set...”

If the information exists it will need to be completely covered over prior to delivery with a label, opaque tape OR a black marker since the master carton will never be sent to a QVC customer.

The following image represents a compliant master carton label:



<b>FROM:</b> VENDOR ABC 1234 MAIN STREET ANYTOWN, FL 54321	<b>QVC P.O. #:</b> 123456 <b>Carton Quantity:</b> 30
<b>TO:</b> QVC, INC. WILROY INDUSTRIAL PARK QVC DRIVE SUFFOLK, VA 23434	
 A23456 890123	

**Figure 23 - Compliant Master Carton Label**

### 8.3.2. Use of Carton Markings Versus A QVC Master Carton Label

QVC always prefers a separate master carton label be used instead of carton markings. However, QVC will accept all required master carton information displayed as carton markings in lieu of a separate master carton label with the exception of the actual bar code itself which must be printer-generated using black ink on white label stock.

When carton markings are used in lieu of a master carton label, the following requirements must be followed:

1. The bar code label must be placed on the same side and in close proximity to the carton markings.
2. All QVC required master carton information must be printed on the same side.
3. If carton markings already exist on a master carton and a standard QVC master carton label is also used, the carton markings may not conflict with information on the QVC label.
4. Lettering height of carton markings must be a minimum of ½ inch (1.27 cm).

### 8.3.3. Master Carton Label Placement

The below requirements must be met for master carton label placement:

1. Place label on the smallest, flattest surface of the carton except if this is the top (open end of carton) or bottom of the carton in which case the label must then be applied to the middle size side panel.
2. Label placement must be consistent from unit to unit.
3. Only one label is required per master carton.
4. DO NOT place label across a carton seam OR around a carton edge.
5. DO NOT place clear tape over the bar code label as this could interfere with successful scanning of the bar code label.



## QVC QA Packaging & Labeling Guidelines – All Commodities

- DO NOT place the master carton or any other label directly in the lower left corner of the master carton as QVC must place a small bar code there upon receipt into a DC for tracking purposes.

**NOTE:** If a master carton is placed on a pallet the barcode label must face outward so it's visible.

The following images represent compliant placement of master carton labels:

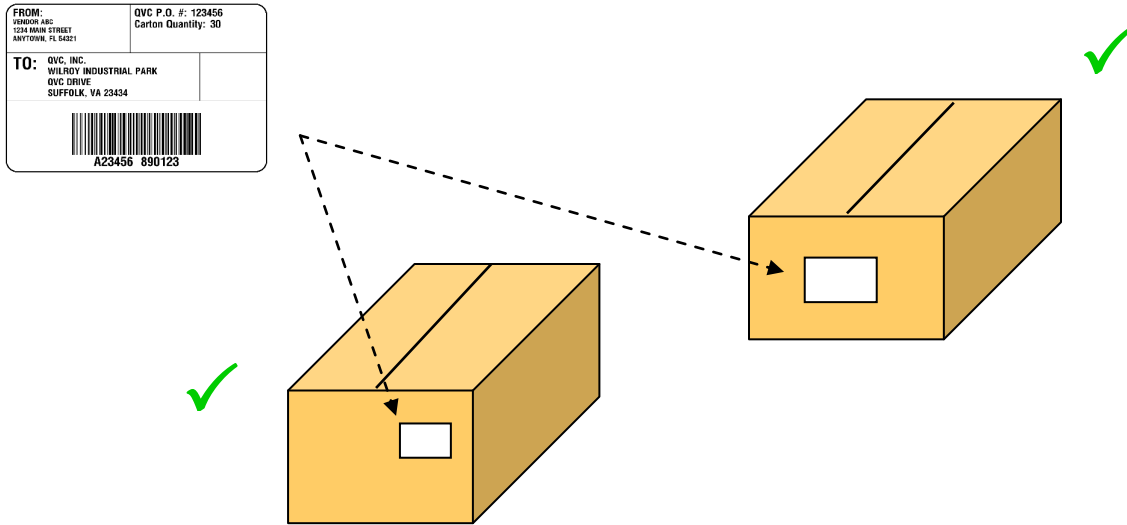

**Figure 24 - Compliant Master Carton Labeling**

The following images represent non-compliant placement of master carton labels:

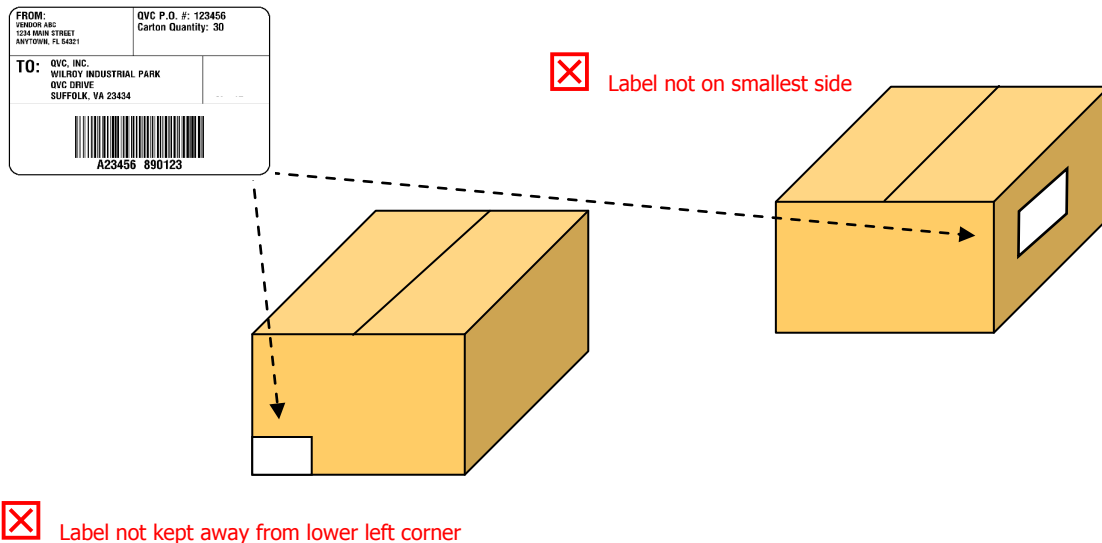

**Figure 25 - Non-Compliant Master Carton Labeling**

### 8.4. The Pallet Label



## QVC QA Packaging & Labeling Guidelines – All Commodities

Although QVC does not require vendors to use pallets to ship product into a DC, a pallet label is required when pallets are used. A bar code is not required on a pallet label. QVC will only accept printer generated labels. Handwritten labels are not acceptable.

### 8.4.1. Pallet Label Requirements

A pallet label MUST have the following information:

1. The “Ship To” address of the QVC distribution center as indicated on the QVC purchase order.
2. Vendor “Ship From” address.
3. The QVC 6-digit Purchase Order number.
4. The complete QVC SKU in a human readable format.
5. The total quantity of individual saleable units contained on the pallet. The quantity must be displayed as a number only, do not use the words “Units”, “Pieces”, “PCS” etc.
6. The phrase ‘DO NOT BREAKDOWN’
7. If a partial pallet is required, the word ‘PARTIAL’ must be boldly and legibly marked on the label and the quantity of units is adjusted accordingly.
8. All required information must have a minimum lettering height of ¼ inches (0.635 cm)

If shipping a partial pallet that will contain mixed SKUs from a single PO, the following additional information must be on the pallet label:

1. “PARTIAL PALLET CONTAINS MIXED SKUS”.
2. Show all complete QVC SKUs contained on the pallet in a human readable format.

---

**NEVER mix SKUs from multiple purchase orders onto a single pallet.**

---

The following image is an example of a compliant pallet label:

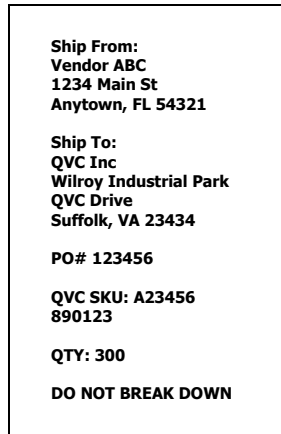

**Figure 26 - Compliant Pallet Label**

The following image is an example of a compliant pallet label with mixed SKUs:

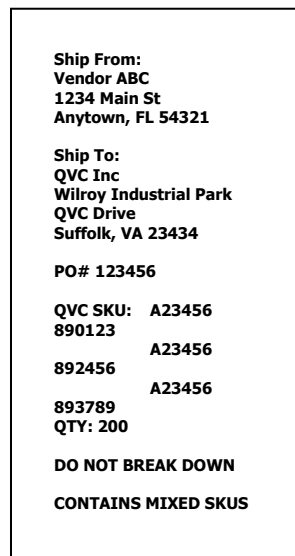

**Figure 27 - Compliant Pallet Label for Mixed SKU's**

#### 8.4.2. Pallet Label Placement

The below requirements must be met for pallet label placement:

1. Place label OVER shrink wrap.
2. Label placement must be consistent from pallet to pallet.
3. Only one label is required per pallet.



### 8.4.3. Multiple Box Items

Multiple box items, which are sold by QVC as one saleable item, require special markings. An example is a computer system, in which a monitor, printer and CPU are sold as one item, but each component is packaged in a separate box. Each box must contain a QVC saleable unit barcode label and be marked “Box 1 of 3”, “Box 2 of 3” and “Box 3 of 3” as appropriate. Wherever possible, vendors are requested to clearly distinguish the components, for example by easily distinguishable carton graphics and colors.

Each box within a multiple-box item must pass the ISTA package integrity tests. QVC cannot overpack any of the individual boxes within a multiple-box item, unless all of the individual component boxes can fit together inside a QVC stock box. Multiple-box items are relatively rare for QVC. Usually, a representative from the QVC Traffic, Supply Chain, Packaging Engineer or Distribution Departments will coordinate the shipment and palletization of multiple-box items with the vendor.

In order to avoid inventory and shipping errors, multiple-box items must be consolidated on a pallet as the saleable item, for example by placing six monitors, six printers and six CPUs together on one pallet.

## 8.5. Pre-Existing Vendor Carton Labels

QVC understands that vendors use and rely on their own internal labeling for processing and shipping product (e.g. UCC-128). If a vendor label exists on any saleable unit or master carton delivered into a QVC distribution center the label must be placed on a different side than the QVC label. In addition, if QVC specific information is used on a vendor’s internal label that information may NOT conflict with the information contained on the QVC label (e.g. QVC SKU, quantity, purchase order number).



## 9. QVC Barcode Format Requirements

In order for QVC to receive product it is vital that the correct barcode labels are used. Verified Label & Print and Fineline Technologies are QVC’s two approved label suppliers. Using one of QVC’s approved label suppliers will ensure barcode format accuracy.

**NOTE:** Most of the barcode requirements mentioned in section nine are specific to accessories, apparel, hardgoods, cosmetics and home textile product lines. Section ten of this document lists special labeling requirements specific to Jewelry only.

### 9.1. Approved Label Suppliers

QVC has two approved bar code label suppliers who can print all required bar code labels at the vendor’s expense. Vendors are responsible for contacting the supplier directly to place the label order.

Any vendor whose first QVC purchase order was created on/after 1/1/2008 is required to order all bar code labels from an approved label supplier for all QVC purchase orders.

<b>Verified Label &amp; Print</b> 6302 Benjamin Road, Suite 411 Tampa, FL 33634 <b>Phone:</b> 813-290-7721 <b>Toll Free:</b> 800-764-6110 <b>Email:</b> <a href="mailto:customerservice@verifiedlabel.com">customerservice@verifiedlabel.com</a>	<b>FineLine Technologies</b> 3145 Medlock Bridge Road Norcross, GA 30071 <b>Phone:</b> 678-969-0835 <b>Toll Free:</b> 800-500-8687 <b>Email:</b> <a href="mailto:support@finelinetech.com">support@finelinetech.com</a>
<b>FineLine Technologies (Hong Kong)</b> Unit A, 10/F, Manning Industrial Building, 116-118 How Ming Street, Kwun Tong, KLN, Hong Kong <b>Phone:</b> 852-2156-9788 <b>Email:</b> <a href="mailto:support@finelinetech.hk">support@finelinetech.hk</a>	

### 9.2. Displaying The QVC SKU In A Human Readable Format

All labels, whether they contain a bar code or not, must have the QVC SKU shown in a human readable format. The QVC SKU is a 13 character alpha-numeric code that identifies an individual saleable unit. The SKU represents 3 components:

Item number (SKN)	characters 1 up to 7
Color/Type code	characters 8 thru 10
Size code	characters 11 thru 13



## QVC QA Packaging & Labeling Guidelines – All Commodities

When printed on a label, the human readable QVC SKU must reflect the proper spacing requirements so that the QVC SKU always reads as a 13 character alphanumeric code.

**Figure 28 - QVC SKU with 7-character SKN**

	1	2	3	4	5	6	7	8	9	10	11	12	13
<b>SKU:</b>	A	1	2	3	4	5	6	0	0	0	0	0	0

└──────────────────┘
└───┘
└───┘

QVC SKN
Color/Type
Size

**Figure 29 - QVC SKU with 6-character SKN**

Characters:	1	2	3	4	5	6	7	8	9	10	11	12	13
<b>SKU:</b>	A	1	2	3	4	5		0	0	0	0	0	0

└──────────────────┘
↑  
space
└───┘
└───┘

QVC SKN
Color/Type
Size

**Figure 30 - QVC SKU with 5-character SKN**

Characters:	1	2	3	4	5	6	7	8	9	10	11	12	13
<b>SKU:</b>	A	1	2	3	4			0	0	0	0	0	0

└──────────────────┘
↑  
space
↑  
space
└───┘
└───┘

QVC SKN
Color/Type
Size

**NOTE:** The QVC SKU spacing requirements described above supersede all SKU spacing as it appears on any other QVC document (e.g. QVC Purchase Order, QA Evaluation report).

### 9.3. General Bar Code Label Requirements





The following barcode label requirements must be met at all times:

1. All individual saleable units and master cartons must have bar code labels.
2. The bar code format must be the same on both label types when shipping saleable units in master cartons.
3. All bar codes must be printed in black ink on a white label.
4. Do not print the labels on glossy label stock. Glossy label stock interferes with the QVC scanners' ability to read bar codes.
5. Do not use shiny ink when printing the bar codes. Shiny ink interferes with the QVC scanners' ability to read bar codes.
6. Do not print the bar codes directly onto corrugate. Overhead scanners frequently cannot read these types of bar codes.

### 9.4. Bar Code Formats

QVC accepts the following three bar code formats, each shown with a QVC SKU in a human readable format:



**Figure 31 - Barcode Formats**

#### 9.4.1. Code 128B Requirements

QVC uses a Code 128, subset B (C128B) bar code format within all distribution centers. The full QVC SKU is encoded into the C128B bar code.

The C128B bar code must meet the following specifications:

1. Minimum bar code dimensions of 2.75 inches (L) x 1.00 inch (H).
2. Minimum ANSI grade C when inspected with a bar code verifier (QVC uses a verifier that complies with ANSI's "Guideline for Bar Code Quality" (ANSI X3.182)" method for verification.
3. Minimum quiet zone of 0.25 (1/4) inches to the left and right of the bar code (see Figure 1)
4. Human readable QVC SKU centered, either above or below the bar code using a minimum 0.125 (1/8) inch character height.



B)

Figure 1 - Code 128B Saleable Unit Bar Code Label Sample:

### 9.4.1.1. Encoding the QVC SKU into a C128B bar code

The QVC SKU number is a 13 character alpha-numeric code representing three components:

1. Item number (SKN) characters 1 up to 7
2. Color/Type code characters 8 thru 10
3. Size code characters 11 thru 13

---

**NOTE:** If color/type and/or size are not applicable to your product the characters default to zeros.

---

The QVC C128B bar code is encoded with the 13 character QVC SKU. QVC considers a space to be a character. Depending upon the length of the QVC Item number, it may be necessary to include a space within the QVC SKU to achieve the full 13 characters. (See Figures 2 - 4)

Figure 2 - SKU with 7 character SKN (Ex. A123456):

Characters:	1	2	3	4	5	6	7	8	9	10	11	12	13
<b>SKU:</b>	<b>A</b>	<b>1</b>	<b>2</b>	<b>3</b>	<b>4</b>	<b>5</b>	<b>6</b>	<b>0</b>	<b>0</b>	<b>0</b>	<b>0</b>	<b>0</b>	<b>0</b>

QVC SKN
Color/Type Code
Size Code

Figure 3 - SKU with 6 character SKN (Ex. A12345):

Characters:	1	2	3	4	5	6	7	8	9	10	11	12	13
-------------	---	---	---	---	---	---	---	---	---	----	----	----	----

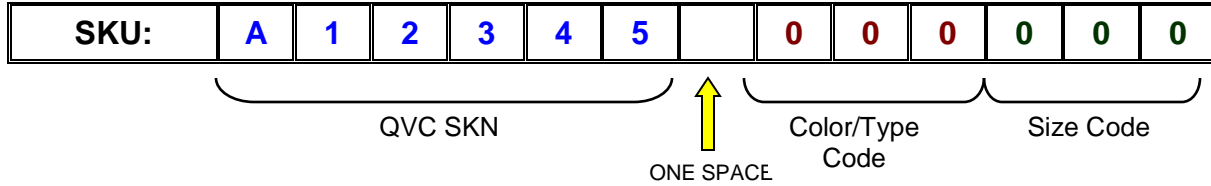

**Figure 4 - SKU with 5 character SKN (Ex. A1234):**

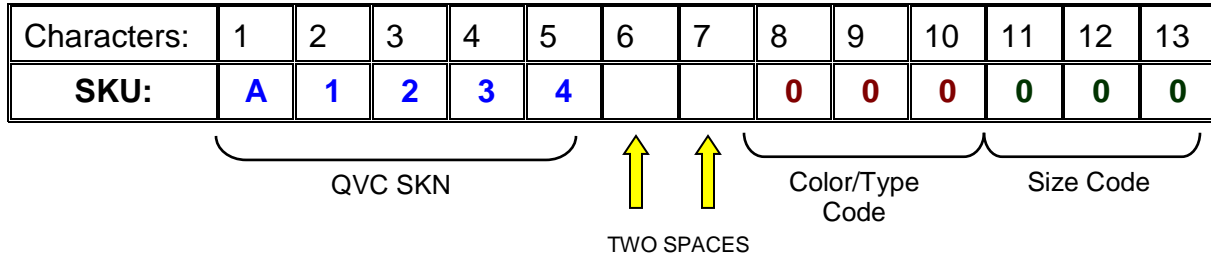

### 9.4.2. UPC-A & EAN-13 requirements

QVC accepts the UPC-A bar code format of the Universal Product Code (UPC). QVC does not supply vendors with UPC numbers. UPC numbers are assigned to specific products and manufacturers by the Uniform Code Council.

QVC also accepts the EAN-13 bar code format which is the European version of the UPC-A. The European Article Numbering (EAN) system uses a similar encoding scheme as UPC codes but the numbers are assigned by agencies overseas that are similar to the Uniform Code Council.

**NOTE:** Never encode a UPC-A or EAN-13 bar code with the QVC SKU.

A UPC-A (Figure 5) and EAN-13 (Figure 6) bar code must meet the following requirements:

1. Minimum bar code dimensions of 1.50 inches (L) x 1.00 inch (H).
2. Minimum ANSI grade accepted is a C when inspected with a bar code verifier (QVC uses a verifier that complies with ANSI's "Guideline for Bar Code Quality" (ANSI X3.182) method for verification.)
3. Minimum quiet zone of 0.25 (1/4) inches to the left and right of the bar code. (Refer to Figure 1, Section 9.7).
4. Human readable QVC SKU placed either above or below the bar code using at least 0.125 (1/8) inch character height.
5. Cross Reference Data as required in the Required Cross Reference Data, see section [Required Cross Reference Data](#).



Figure 5 – UPC-A Sample:



Figure 6 – EAN-13 Sample:

---

**NOTE:** There are no specified size requirements for the actual label as long as the aforementioned specifications are followed.

---

### 9.5. Required Cross Reference data

When using a UPC-A or EAN-13 bar code, the vendor is responsible for providing cross-reference data showing the relationship between each QVC SKU and its corresponding UPC/EAN codes. The cross reference data must be submitted BEFORE a vendor’s product arrives at a QVC distribution center.

The cross-reference data must be emailed to [supplychain@qvc.com](mailto:supplychain@qvc.com) and [vendorcompliance@qvc.com](mailto:vendorcompliance@qvc.com) in an Excel spreadsheet and contain the QVC SKN, Color/Type code, Size code and the UPC or EAN code in the format shown in Figure 7.

Figure 7 - Excel Cross Reference File

QVC SKN	Color/Type code	Size code	UPC or EAN code
A1234	000	545	123456789012
H01234	012	000	234567891011



## 9.6. Bar Code Approval processes

QVC does not review or approve bar code labels for vendors. Bar code labels included on a product submitted for QA 1st Piece Sample Evaluation or Top of Production (TOP) will not be reviewed or commented on within the final evaluation report.



## 10. Jewelry; Special Labeling & Barcode Format Requirements

The following specifications must be met for bar code labels applied to a saleable unit, inner pack and master carton. Bar codes are not required on pallet labels.

### 10.1. Approved Label Suppliers

See section [Approved Label Suppliers](#).

### 10.2. General Bar Code Label Requirements

The following barcode label requirements must be met at all times:

1. Only a Code 128, subset B (C128B) bar code format is accepted.
2. The full QVC SKU must be encoded into the bar code and properly spaced to always read/scan at 13-characters. See section [Encoding the QVC SKU into a C128B barcode](#).
3. The full QVC SKU in a human readable format properly spaced and centered below the bar code.
4. Minimum ANSI grade C when inspected with a bar code verifier.
5. Minimum quiet zones of ¼ inches to the left and right of the bar code.
6. All bar codes must be printer generated using white label stock and black ink.
7. DO NOT print the labels on glossy label stock or use shiny ink as it can interfere with the QVC scanners' ability to read the bar code.

### 10.3. Saleable Unit Bar Code Specifications

A saleable unit label MUST contain the following:

1. Follow all requirements as listed under General Bar Code Label Requirements.
2. Bar Code dimensions MUST measure 1<sup>5</sup>/<sub>8</sub> inches (W) x <sup>5</sup>/<sub>8</sub> inches (H) exactly.
3. Label dimensions MUST measure 2¼ inches (W) x 1.0 inch (H) exactly.
4. Lettering height of the human readable QVC SKU must be a minimum of <sup>1</sup>/<sub>8</sub> inch.



### 10.3.1. Saleable Unit Label placement

When placed on a polybag, the saleable unit bar code label should be placed in the center of the bag.

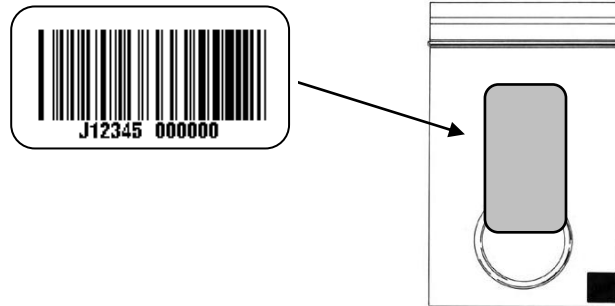

**Figure 32 - Example of proper placement for Jewelry in a polybag**

When placed on a vendor supplied presentation case, the saleable unit bar code label should be placed centered on the bottom of the case or sleeve. If the bottom of the presentation case is too small to place a compliant (properly sized) barcode label, the presentation case must be over-packed into self-sealing polybag of a size that will accommodate the label.

## 10.4. Inner Pack Bar Code Specifications

---

**NOTE:** A printer generated barcode is required for jewelry inner carton packaging. Handwritten labels are not acceptable.

---

An inner carton label **MUST** contain the following:

1. Follow all requirements as listed under General Bar Code Label Requirements.
2. Bar Code dimensions may not be less than 1<sup>5</sup>/<sub>8</sub> inches (W) x 5<sup>5</sup>/<sub>8</sub> inches (H).
3. Lettering height of the human readable QVC SKU must be a minimum of 1/4 inch.
4. Label dimensions should not exceed 4 inches (W) x 2 inches (H).
5. The quantity of saleable units contained within the inner pack which is to be expressed as a number only. **DO NOT** use the words units, pieces, sets etc.
6. If a partial inner pack is required, the word 'PARTIAL' must be boldly and legibly marked on the label and the quantity of units adjusted accordingly.



Figure 33 - Compliant Jewelry Inner Carton Label

#### 10.4.1. Inner Carton Label Placement

See section [Inner Carton Label Placement](#).

### 10.5. Master Carton Bar Code Specifications

A master carton label MUST contain the following:

1. Follow all requirements as listed under General Bar Code Label Requirements.
2. Bar Code dimensions may not be less than  $1\frac{5}{8}$  inches (W) x  $\frac{5}{8}$  inches (H).
3. Lettering height of the human readable QVC SKU must be a minimum of  $\frac{1}{4}$  inch.
4. Label dimensions should not exceed 6 inches (W) x 4 inches (H).

#### 10.5.1. Master Carton Label Placement

See section [Master Carton Label Placement](#).

### 10.6. Pallet Label Specifications

See [The Pallet Label](#).

Questions regarding the information addressed in this chapter should be directed to the QA Packaging team at [QVCQAPackaging@qvc.com](mailto:QVCQAPackaging@qvc.com)

Any deviations to these requirements must be approved by the QVC QA Packaging Engineer prior to shipment.